

# PTC Thermistors

## Easy Thermal Management in Driver Circuits of LED Lighting Applications

The PTC thermistors of the series A603 and A602 are specially designed for use in electronic drivers for LED lighting applications. As required by this application they share the feature of a very tight resistance tolerance of  $\pm 15\%$ , a value not reached by any other comparable standard product in the market. In addition their R/T curve is well specified in the relevant temperature range.

Additionally to these new products we also present our limit temperature sensors A601, which are suited to support designers producing outstanding reliable LED drivers.

### Applications

- Automotive lighting
- Backlighting in large panels, mobile phones, notebooks

- Traffic signals
- Architectural and interior lighting

### Features

For LED PTC thermistor A603 and A602

- Chip size 0603
- Tight resistance tolerance of  $\pm 15\%$
- Well defined resistance vs. temperature curve
- RoHS-compatible

For limit temperature sensor A601

- Chip size 0603
- Approved acc. to UL 1434
- RoHS-compatible
- Lead free (total Pb content  $< 0.1\%$ ) except  $T_{\text{sense}} = 135\text{ °C}$

# Easy Thermal Management in Driver Circuits of LED Lighting Applications

PTC thermistors and their pronounced change in resistance with temperature are ideally suited to control the LED forward current in all kinds of lighting applications. They can e.g. be used to realize a derating of the forward current at high temperatures to protect the LED chip from damage or accelerated aging. Alternatively they can be used to realize a simple over temperature protection.

All PTC thermistors presented below are intended to be used in a secondary circuit, in order to avoid self heating by the load current.

Typical R/T curve of a PTC thermistors

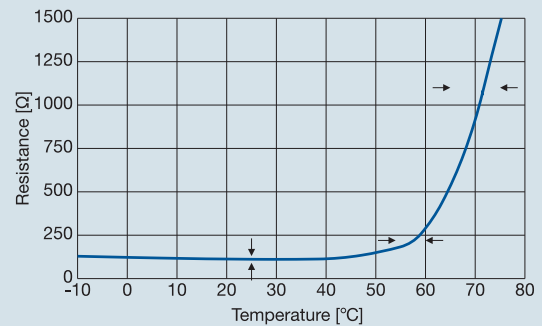

Two circuit examples

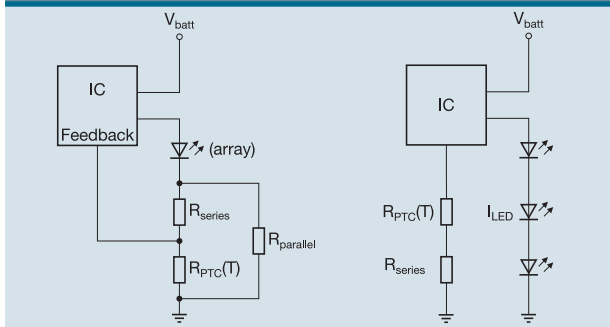

Example of PTC controlled LED current

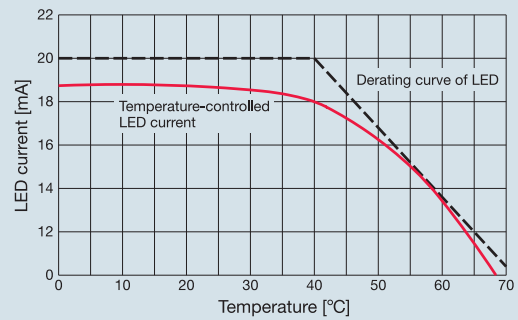

## Technical data

R <sub>R</sub> Ω	T @ R <sub>min</sub> °C	T @ 2 · R <sub>R</sub> °C	T <sub>Sense</sub> °C	ΔT °C	R (T <sub>Sense</sub> - ΔT) kΩ	R (T <sub>Sense</sub> + ΔT) kΩ	V <sub>max</sub> V	Ordering code
<b>Series A603 and A602 for LED thermal management (EIA 0603)</b>								
470 ±15%	5	45 ± 5	55	5	< 4.7	> 4.7	32	B59603A0055A062
470 ±15%	40	75 ± 5	85	5	< 4.7	> 4.7	32	B59603A0085A062
470 ±15%	55	95 ± 5	105	5	< 4.7	> 4.7	32	B59603A0105A062
110 ±15%	15	57 ± 3	70	5	< 1.1	> 1.1	32	B59602A0055B062
<b>Series A601 for general temperature sensing (EIA 0603)</b>								
R <sub>R</sub> Ω	T <sub>Sense</sub> °C	R (T <sub>Sense</sub> - 5 °C) kΩ	R (T <sub>Sense</sub> + 5 °C) kΩ	V <sub>max</sub> V	Ordering code			
470 ±50%	75	< 4.7	> 4.7	32	B59601A0075A062			
470 ±50%	85	< 4.7	> 4.7	32	B59601A0085A062			
470 ±50%	95	< 4.7	> 4.7	32	B59601A0095A062			
470 ±50%	105	< 4.7	> 4.7	32	B59601A0105A062			
470 ±50%	115	< 4.7	> 4.7	32	B59601A0115A062			
470 ±50%	125	< 4.7	> 4.7	32	B59601A0125A062			
470 ±50%	135	< 4.7	> 4.7	32	B59601A0135A062			

**Important information:** Some parts of this publication contain statements about the suitability of our products for certain areas of application. These statements are based on our knowledge of typical requirements that are often placed on our products. We expressly point out that these statements cannot be regarded as binding statements about the suitability of our products for a particular customer application. It is incumbent on the customer to check and decide whether a product is suitable for use in a particular application. This publication is only a brief product survey which may be changed from time to time. Our products are described in detail in our data sheets. The Important Notes (www.epcos.com/ImportantNotes) and the product-specific warnings and cautions must be observed. All relevant information is available through our sales offices.