

For increasing the clearance of capacitors with screw terminals M10; minimum distance between the terminals: 35 mm.

Suitable for case types B 25 834-+★★★★-K4 and  
B 25 838-+★★★★-K4.

The insulating parts are made of polyamide.

With the aid of these insulating parts a given clearance of  $L = 13$  mm can be increased to a clearance of  $L = 25$  mm. Two insulating parts are required for each capacitor.

## Insulating part

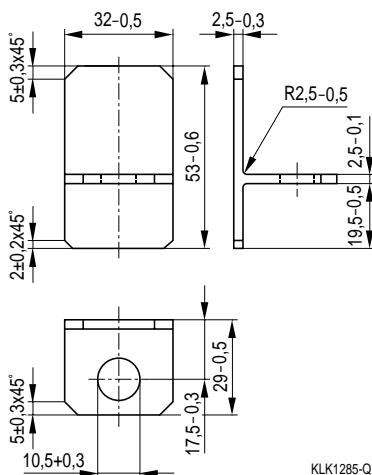

KLK1285-Q

## Application example

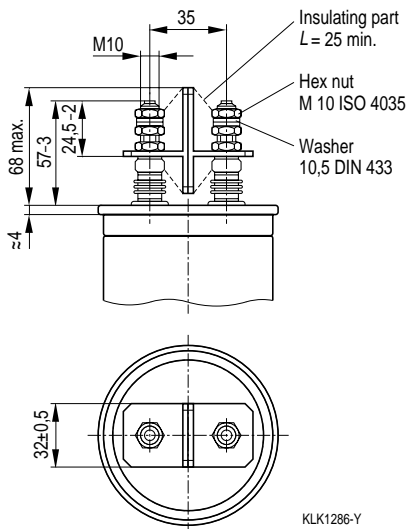

KLK1286-Y

Dimensions in mm

**Ordering code:** B25901-A1

(Ordering code per piece, 2 are required)

