



Application Notes

PQS



Spinning PFC – Case Study Nahar Spinning Mills

P o w e r Q u a l i t y S o l u t i o n s

The collection of "PQS Application Notes" is a library with in-depth information on PFC applications, case studies and reference projects. It also serves as a helpdesk for all topics relating to PFC and PQS, is suitable for training purposes and is designed to answer frequently asked questions.

Each issue will focus on a particular application topic, a specific solution or a topic of general interest. The aim is to share the extensive knowledge gained globally by EPCOS PFC experts with regional staff who deal with PFC and PQS. The authors of the PQS Application Notes have extensive experience in the field of PFC and PQS and a professional background as electrical/design engineers or product marketing managers throughout the world.

These PQS Application Notes are issued from time to time and can be downloaded from the EPCOS Internet under www.epcos.com/pfc

Please contact the EPCOS PM department in Munich if you wish to receive the latest issue of the PQS Application Notes automatically by e-mail. A list with available titles may also be obtained from the PM department in Munich.

Important Notes

Some parts of this publication contain statements about the suitability of our products for certain areas of application. These statements are based on our knowledge of typical requirements that are often placed on our products for a particular customer application. It is incumbent on the customer to check and decide whether a product is suitable for use in a particular application. This Application Note may be changed from time to time without prior notice. Our products are described in detail in our data sheets. The Important Notes (www.epcos.com/ImportantNotes) and the product specific warnings and cautions must be observed. All relevant information is available through our sales offices.

Foreword

It's hard to find an industry as old as textiles. Emerging from pure handicrafts – mainly for domestic requirements – it now ranks amongst the top industries worldwide.

The tremendous growth of the textile industry with its high-tech machinery has naturally led to a high consumption of electric power. In the early days of the industry, natural resources seemed to be endless – a fatal error, as the climate change we are now experiencing shows.

Nahar Spinning Mills Ltd. is a market leader in the Indian textile industry. While honoring a long tradition, it has the foresight to invest in the future. It decided not only to increase its production capacity but also to invest in solutions to reduce power consumption. The immediate effects have already shown that this foresight has paid off – and will do so even more in the near future.



The Author

Rajneesh Shukla, Engineer in Electricals & Electronics and MBA with 10 years of engineering experience and 7 years in PFC marketing within EPCOS. He is responsible for business development in the Delhi region.

Contents

Tradition and progress	5
1. PFC and the textile industry	5
■ Textile industry	5
■ Spinning wheel.....	5
■ A new era	5
■ High competition on the world market.....	5
■ Stability of the power supply	5
2. The company	5
■ Nahar Spinning Mills Limited	5
■ New opportunities	5
■ Capital expenditure	5
■ Environmental protection	5
3. Starting position	5
■ Customized PFC system.....	5
■ In-house power generation	5
■ New Laxmi Electric and International Switchgear.....	6
■ Mix of capacitor technologies.....	6
■ Installation at different locations.....	6
4. Results	6
■ Objective targets	6
■ Secondary effects	6
■ Payback period	6
5. Conclusions	6
6. Standards	8

Power Factor Correction

Spinning PFC – Case Study Nahar Spinning Mills

Nahar Spinning Mills is an enterprise steeped in **tradition** – but which has taken an important step towards **progress**. It has decided to invest in power quality solutions and environmental protection as well as other aspects of the business.

1. PFC and the textile industry

The **textile industry** is made up of manufacturing enterprises producing fabrics made of natural raw materials (plant fibers such as jute, flax, cotton and sisal or animal fibers such as lambswool and silk).

It is one of the oldest branches of industry – in the early days textile products were all hand-made, mainly at home or in small handicraft enterprises.

The first mechanical appliance used in manufacturing was the **spinning wheel** invented in the 14th century. The 18th century then brought a revolution in spinning when James Hargrave built the *Spinning Jenny* in 1767 – the first spinning machine (named after his little daughter). This was the beginning of a **new era** for the textile industry.

Today, most fabrics are produced in China, India and Taiwan. India in particular, whose historical associations include Mahatma Gandhi and his promotion of the country's cotton industry, has experienced tremendous growth of its textile market. Huge domestic and foreign demand makes it one of the main branches of the Indian economy.

The **tough competition in the world market** makes it indispensable to keep production costs as low as possible. The cost of the electric power supply is an enormous factor, especially for spinning mills with a huge output of cotton yarn. The **stability of the power supply** must also be guaranteed – a band stoppage due to voltage sags can easily result in red figures at the end of the day.

This is where power factor correction comes into the picture. A customized PFC design helps producers keep on top of the market by:

- Reducing the amount of reactive power in the grid → less energy consumption → lower energy costs
- Stabilizing the power supply → avoidance of voltage sags → no band stoppages
- Protecting manufacturing equipment by eliminating high inrush currents → no investments for replacement machinery

2. The company

Nahar Spinning Mills Limited, established in 1949, is an enterprise with a fine tradition of quality and innovation.

Chairman Jawahar Lal Oswal says: “Today we are facing new challenges, but also **new opportunities**. At Nahar, we want to make use of new technologies to continue our dedication to quality, our employees and the environment. We are planning **capital expenditures** of around €140 million within the next two years to increase our capacity and find solutions for **environmental protection**.”



Fig. 1: Jawahar Lal Oswal, Chairman of Nahar Spinning Mills Ltd., India

3. Starting position

This management strategy led to the decision to implement a **customized PFC system** to enhance the prevailing conditions of the grid, e.g. to reduce the maximum demand of 3,600 kVA and increase the present power factor of 0.84.

The 11 kV supply stepped down to 433 V gives Nahar Spinning Mills Ltd. an **in-house power generation capacity** of 3.2 MW. The two existing main transformers of 2 MVA each could easily be coupled together.

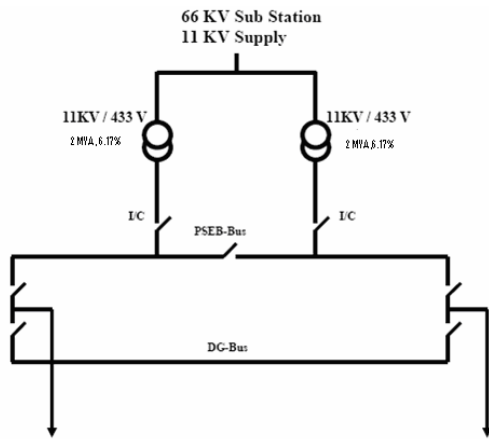

Fig. 2: Single-line diagram of the system

Various loads: B/R preparatory, R/F-1, R/F-4, P/s, TFO-1, TFO-2, lighting etc.

After analyzing the existing conditions, **New Laxmi Electric** (Panjab state) supplied the PFC components manufactured by EPCOS which were installed by **International Switchgear**. To meet the requirements, a mix of capacitor technologies was chosen, a total 1,350 kvar of PhaseCap and SquareCap HD capacitors.

The PFC systems were installed at **different locations** on the spinning mill premises:

- A 200 kvar APFC panel on transformer no. 1
- A 200 kvar APFC panel on transformer no. 2

A 950 kvar unit was fixed with various MCCs (motor control circuits) at the B/R (blow room), the R/F (ring frame) and the TFO (two for one) process, where two threads are combined together to make one.

4. Results

Measurements made after the installation showed that the **targets** had been met:

- Overall grid conditions were improved
- The power factor was improved to 0.98
- kVA demand was reduced by 500 to 3,100 kVA
- The current was reduced by 650 A

As a **secondary effect**, Nahar received an incentive from the Utility Board for successfully reducing the power factor by 12%! This also helped to reduce the **payback period** for investment in the PFC system to less than 6 months!

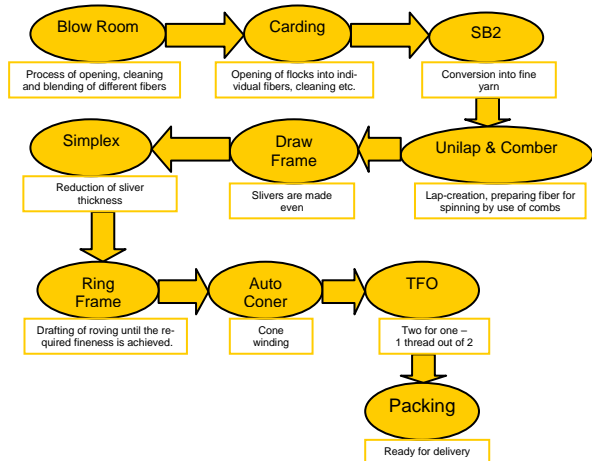

Fig. 3: Spinning mill workflow

5. Conclusions

Investment in the future always requires considerable foresight – we unfortunately possess no crystal ball for this purpose.

As the example of Nahar Spinning Mills shows, an investment can only pay off when several parameters are considered. Production capacity can be doubled or tripled to cope with growing market demand only with a suitable installed base of machines. There is no point in extending this when the power quality has reached its limits. Failures in the power supply inevitably cause problems in the production process, such as band stops caused by voltage drops or breakdowns.

For Nahar, the investment in PFC has already paid off in the incentives obtained from the Utility Board and the higher power quality now available. The management is already highly satisfied with the outcome of their investment – and is now planning to improve the installation by fitting a detuning system to reduce the content of harmful harmonics in the grid, thus achieving even better power quality.



Application Notes

Spinning PFC – Case Study Nahar Spinning Mills

EPCOS supplies all the key components for a successful PFC solution – with our global partners we have built up a network of experts for Power Quality Solutions who have the expertise to find answers to all application-related questions.

One thing should always be kept in mind: enhancement of power quality is not only of financial benefit to the user – it also helps to save natural resources and is a proven means of protecting the climate.

6. Standards

The recommendations and proposals stated in this Application Note are based (amongst others) on several international standards for PFC capacitors, LV switchgear design and electrical systems:

- IEC60831: LV-PFC Capacitor Standard
- IEC61921: Power Capacitors LV PFC banks
- DIN EN61921: Leistungskondensatoren Kondensatorbatterien zur Korrektur des Niederspannungsleistungsfaktors
- EN 50160: Voltage Characteristics of Electricity Supplied by Public Distribution Systems
- Engineering Recommendation G5/4: Planning levels for harmonic voltage distortion and the connection of non-linear equipment to transmission systems and distribution networks in the United Kingdom
- IEEE Standard 519-1992: IEEE Recommended practices and requirements for harmonic control in electrical power systems
- IEC60439-1/2/3: Low-voltage switchgear and control gear assemblies

The specifications in the standards and manufacturers' data sheets should always be observed.

Published by
EPCOS AG
Product Marketing PFC
P.O. Box 80 17 09
D-81617 Munich/Germany