

Applications & Cases

Triplexers for mobile communication and reception of GPS signals

January 2006

Pinpoint detection



Photo: Motorola

PROFILE	TRIPLEXERS
<p>The D1034 triplexer has been developed for simultaneous GPS reception and data transmission on the North American mobile phone bands and IMT-2000 via a common antenna.</p>	
Insertion loss:	0.6 dB
Frequency bands:	CEL (824 to 894 MHz) GPS (1575 MHz) and PCS (1850 to 1990 MHz)
Dimensions:	3.2 × 3.2 × 1.6 mm
Technology:	Low-temperature co-fired ceramics (LTCC)
	

Location-based value-added services are seen as the future of mobile telephony. The ability to receive GPS signals is an essential precondition. EPCOS offers a module with a footprint of 3.2 × 3.2 mm for simultaneous mobile communication and reception of GPS signals.

Since measures were introduced in the United States under the 911 Act to create a nationwide emergency call infrastructure that includes the mobile phone network (Wireless E911), the exact point of origin of every emergency call must be located and relayed to the emergency call center. The same requirement applies in Canada. Phase II of implementation of the E911 wireless service ran from October 2001 to the end of 2005. Network operators are obliged to relay the exact location of the mobile phone as well as its number. Depending on the technology used, location accuracy of 100 meters is specified for 67% of all emergency calls and 300 meters for 95% of calls. Location accuracy of 50 and 150 meters respectively is specified for procedures implemented in the handsets.

Applications & Cases

Beyond emergencies, location-based services (LBS) open up a host of mobile value-added services.

Network-based procedures

Among the possible techniques for determining location, a distinction is made between network-based and telephone-based procedures. The former, which evaluate the data of the base stations, include cell ID, triangulation and angle of arrival (AOA).

Cell ID: This term refers to the unique identification number of the base station at which the phone is registered. Accuracy of location depends on cell size and can be up to three kilometers. The location radius can be determined more accurately by measuring the delay time of the signals.

Triangulation: Time difference of arrival (TDOA) and enhanced time observed (E-OTD) are triangulation methods. If a mobile phone is situated within range of several base stations, the distance from the respective base station can be deduced by evaluating the delay times or differences between them. At least three base stations are required. The accuracy of positioning here ranges from 50 to 200 meters.

AOA: The angle of arrival of the incoming signals is detected in the base station via sector antennas. At least three base stations are required to attain the accuracy of TDOA or E-OTD.

Telephone-based procedures

The following techniques that can be implemented in mobile phones are currently available:

GPS: A dedicated receiver evaluates the satellite signals. Accuracies between 5 and 30 meters can be attained, but long synchronization times are required during initialization. Reception is also very limited in buildings.

Assisted GPS: Network-supported GPS is used to transmit satellite information from base station to handset. Synchronization can be performed quickly. Weak GPS signals can also be received so that this technique can be used in buildings.

AFLT (advanced forward link trilateration): The differences in delay times of the data streams from at least three base stations are evaluated in the telephone. This assumes synchronization of the base stations and their simultaneous reception in the phone. This technique is thus suitable for CDMA networks. Accuracies between 50 and 200 meters can be attained.

EFLT (enhanced forward link trilateration): Like AFLT, this is used for older mobile phones that do not permit fast time comparison. Due to the lower time resolution, the accuracy is only in the range of 250 to 350 meters.

Major carriers in the USA have opted for implementation of E-OTD in GSM networks and the AFLT/assisted GPS hybrid solution for CDMA.

Applications & Cases

1 | Block diagram of triband CDMA handset

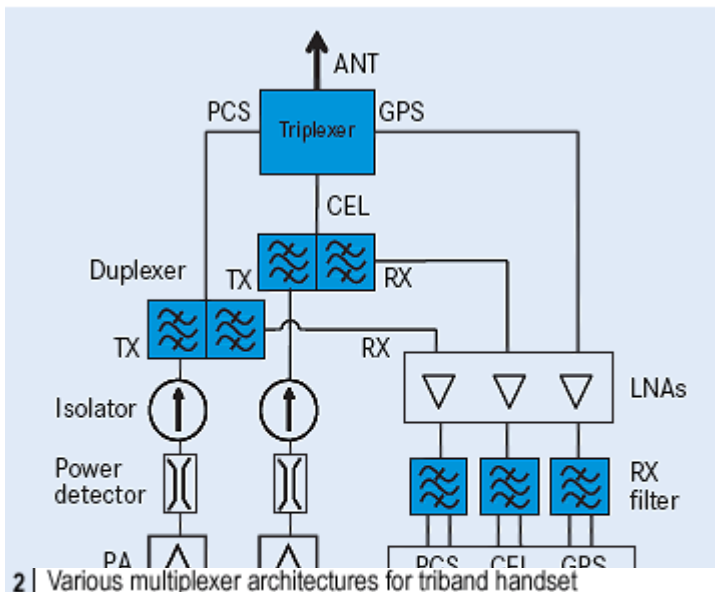

2 | Various multiplexer architectures for triband handset

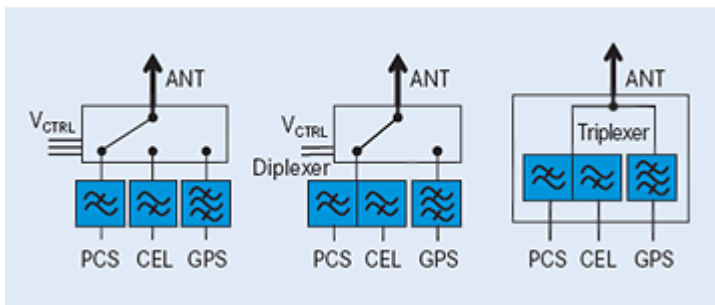

GPS and mobile telephony

Implementation of network-supported GPS calls for integration of an additional receiver in the handset. To withstand the high pressure of miniaturization and costs, the complete GPS receiver is now integrated in the CDMA chipset that operates on only one antenna. The typical architecture of a triple-band phone for CDMA with a GPS receive stage is shown in

→

1. A multiplexer is needed to split the receive signals up again among the various receiver inputs. Various multiplexer designs are shown in → 2. They range from the single-pole triple-through (SP3T) switch through a simple diplexer with a GPS single-pole double-through (SPDT) switch right up to the all-passive triplexer.

Whereas solutions based on switches do not allow simultaneous mobile telephony and GPS reception (S-GPS), a diplexer does offer this option. An important factor is minimum isolation between the mobile radio path and the GPS channel. The diplexer suppresses its own transmit signal on the mobile phone frequencies. If this appears too strong at the GPS input, the receiver is blocked. The suppression at the GPS frequency reduces the noise of the source transmitter. If it is too high, the sensitivity is greatly limited.

EPCOS has developed a module which is also designed as a passive diplexer for simultaneous GPS operation and mobile telephony. Thanks to LTCC technology, this very space-saving solution takes up only 10 mm².

The module splits up the CEL (824 to 894 MHz), GPS (1575 MHz) and PCS (1850 to 1990 MHz) frequency bands. Measuring 3.2 × 3.2 × 1.6 mm, it is distinguished from other solutions by high linearity, as required for CDMA signals, an integrated GPS SAW filter, and very high isolation between the GPS path and the mobile phone bands, without any additional control lines for switching.

Applications & Cases

3 Typical frequency and attenuation curves of D1034 triplexer from EPCOS

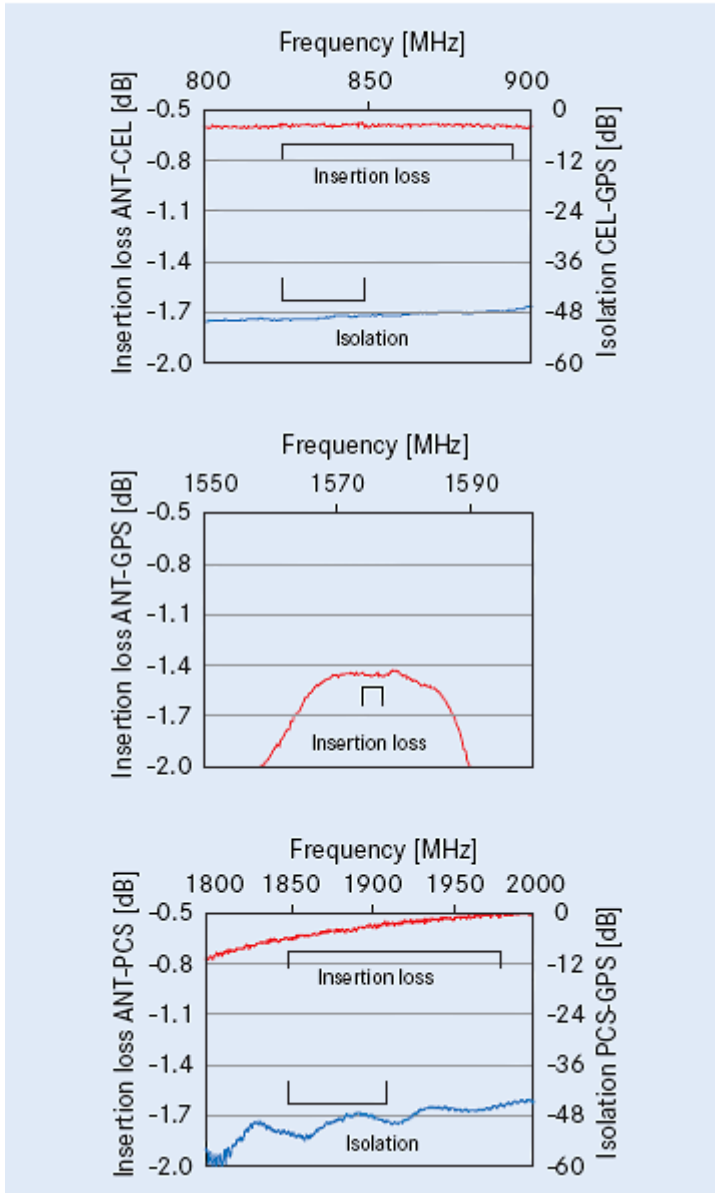

The typical frequency curve of the various paths as well as insertion loss and channel separation is shown in → 3. The high-pass characteristic of the PCS path makes combination with other bands possible. The PCS path can also be used for IMT-2000 frequencies (UMTS) as required. The triplexer then needs no additional matching elements.