

No fear of interference



EPCOS EMC LAB Passing tests with flying colors

The EPCOS test lab offers high-quality services to ensure electromagnetic compatibility (EMC) in electronic equipment. These range from consulting and training programs during the development phase through EMC measurements on prototypes to pre-compliance testing of products manufactured in volume. A well-equipped laboratory in Regensburg, Germany (which also houses Europe's first anechoic chamber, opened in 1963), decades of experience, profound competence in EMC and active involvement in standardization provide a solid basis for meeting exacting customer demands. Two shielded enclosures with four test stations are available for measuring conducted interference, while an absorber-lined anechoic chamber with a measurement range of 10 meters examines airborne interference. Power supplies for up to 100 A, electrical and motor loads, fume extractors and large doors enable a wide variety of equipment and installations to be tested, especially those of large volume and high power.

Modern electronics demands higher and higher levels of electromagnetic compatibility (EMC). With decades of experience in EMC components and customer-oriented services, EPCOS offers solutions for every electromagnetic challenge.

Electromagnetic compatibility is more relevant than ever to electronic design. The rapid growth of power electronics driven by fast semiconductor switches and progressive miniaturization of circuitry, combined with trends toward higher clock frequencies and lower power consumption, calls for intelligent and economical EMC solutions to ensure the functionality of all electronic equipment. Offering one-stop shopping for EMC components, services and consulting, EPCOS supports its customers from the start of product development right up to volume production.

EMC legislation in transition

EMC requirements are defined in the EMC directive of the European Union. The directive is designed to ensure that a wide variety of electronic equipment can be operated without causing or being susceptible to electromagnetic interference. Harmonized standards describe relevant measuring and test procedures as well as mandatory limits for spurious emissions and noise immunity.

Applications & Cases

PORTFOLIO | EMC



Solution package meets standards

Ongoing development of EMC components follows customer demands and innovations in technology against the background of changing laws and standards. Close cooperation with Ferrites, the sister division, assures EPCOS a leading position as a full-range manufacturer of EMC components. The broad spectrum of standard components is complemented by customer-specific components for the special challenges of individual applications.

The new version of the EMC directive is currently being discussed by the European Parliament and expected to be published in late 2004. It contains a series of important changes. Application of harmonized standards will no longer be compulsory. If harmonized standards are not applied, an expert assessment by a competent body will no longer be required either. But if the manufacturer's declaration of conformity is not based on harmonized standards, a conformity assessment procedure must be conducted and documented, and the documentation retained for queries to ensure that the EMC protection requirements are met. Alternatively, conformity assessment may be delegated to a notified body.

→ [Further information](#)

EMC standards are also permanently reviewed and revised. As an active member of several important EMC standardization bodies at national and supranational levels, EPCOS can give its customers first-hand advice.

Competent partner for EMC services

EPCOS has extensive experience of conducting noise voltage measurements not only at its EMC test lab in Regensburg, but also right at the manufacturer's premises. Both items under test and filter circuits, especially those for customer-specific EMC filters, can be modified to comply with limit values. Careful preparation is always needed to obtain results that are just as meaningful and reproducible from an environment that falls short of the best laboratory conditions.

Providing evidence of compliance with applicable EMC standards and regulations, the acceptance report is the basis for the customer's declaration of conformity. The EPCOS EMC test lab is accredited by the German accreditation council DAR and a member of the competent body of Siemens AG. In testing during development in particular, direct cooperation between engineers of the EMC test lab and component designers has proved worthwhile. This results in rapidly optimized, economical solutions. Prompt availability of samples (including modified components) is a key to successful interference suppression.

Frequency converters demand innovative solutions

Frequency converters present EMC filters with a tall order. Modern converters are optimized in terms of power dissipation and size. They make use of higher clock frequencies and faster power semiconductors. These generate steep-edged, high-frequency noise that interacts with the motor connected (including motor cable) to produce high differential-mode interference currents. EMC filters for converters must therefore be designed to cope with high peak currents. Selection and scaling of inductors and capacitors as well as circuit design call for profound knowledge of converter technology, customer requirements and, of course, EMC.

EPCOS therefore creates EMC solutions in close cooperation with customers. The fact that EPCOS was the first components manufacturer to develop and supply filter solutions for new converter technologies such as active front-end (AFE) converters → 1 and remains a leader in such innovative converter topologies testifies to the company's unique competence. EPCOS' edge in EMC filter technology is also reflected in a series of inventions with patents pending.

Applications & Cases

1 | Advanced filter solution for innovative converters

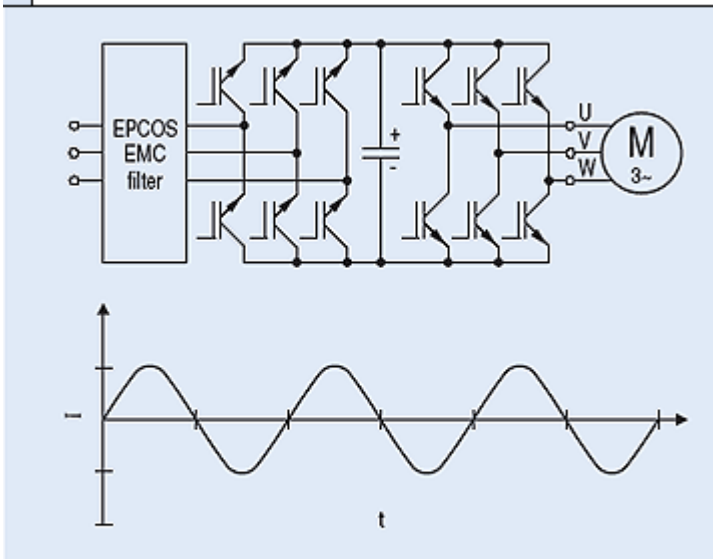

1 | Circuit of an AFE converter with a regulated power rectifier and quasisinusoidal current drawn from the AC line.

Decades of experience in automotive electronics

Data line chokes are found in almost every modern vehicle. Without them, EMC and reliable operation of automotive electronics would no longer be assured. EPCOS offers data line chokes in various designs and package sizes for the exacting requirements of the automobile industry.

Forthcoming deployment of new networking systems in vehicles, such as the more powerful FlexRay system (two-wire bus with transmission rate of about 100 MBit/s), demands even higher levels of electromagnetic compatibility. EPCOS supplies matching components for this application. They assure that operation is just as reliable as in bus systems used so far, such as the CAN bus.