

Preliminary datasheet

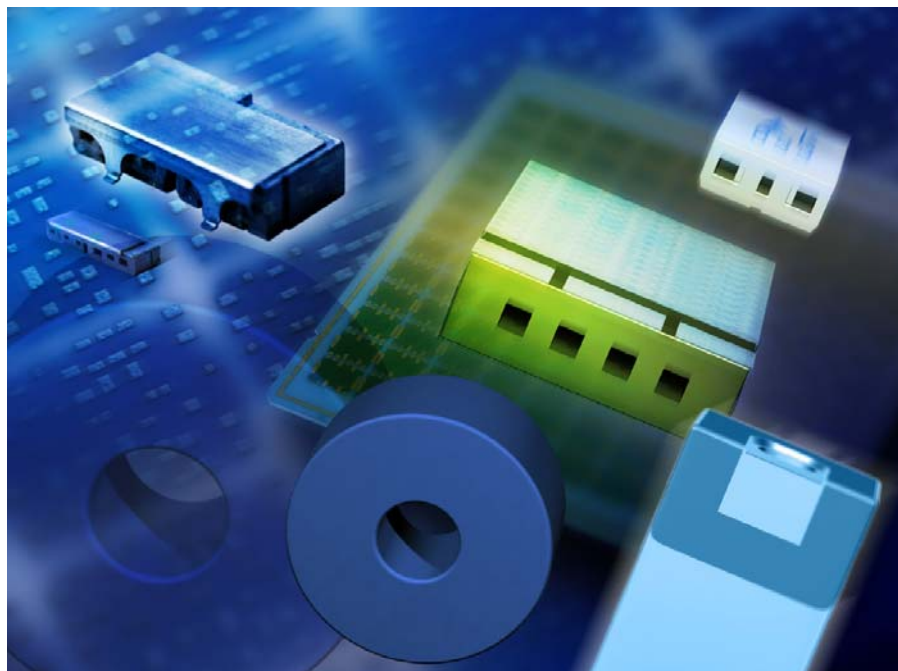

Features

- SMD filter consisting of coupled resonators with stepped impedances
- low losses
- high attenuations at GSM (900, 1800) and UMTS bands
- high attenuation at 2 times center frequency
- (NdBa)TiO₃ ($\epsilon_r = 88 / TC_f = 0 \pm 10$ ppm/K) with a coating of copper (10 μ m) and tin (>5 μ m)
- Excellent reflow solderability, no migration effect due to copper/tin metallization

Index

- Page 2
 - Dimension Limits , Marking
 - Recommended footprint
- Page 3
 - Characteristics
 - Maximum ratings
 - Typical passband characteristic
- Page 4
 - Processing information
 - Soldering requirements
 - Delivery mode

ISSUE DATE	27.08.03	ISSUE	P1	PUBLISHER	SAW MWC PD F	PAGE	1/4
------------	----------	-------	----	-----------	--------------	------	-----

Preliminary datasheet

Dimension Limits , Marking

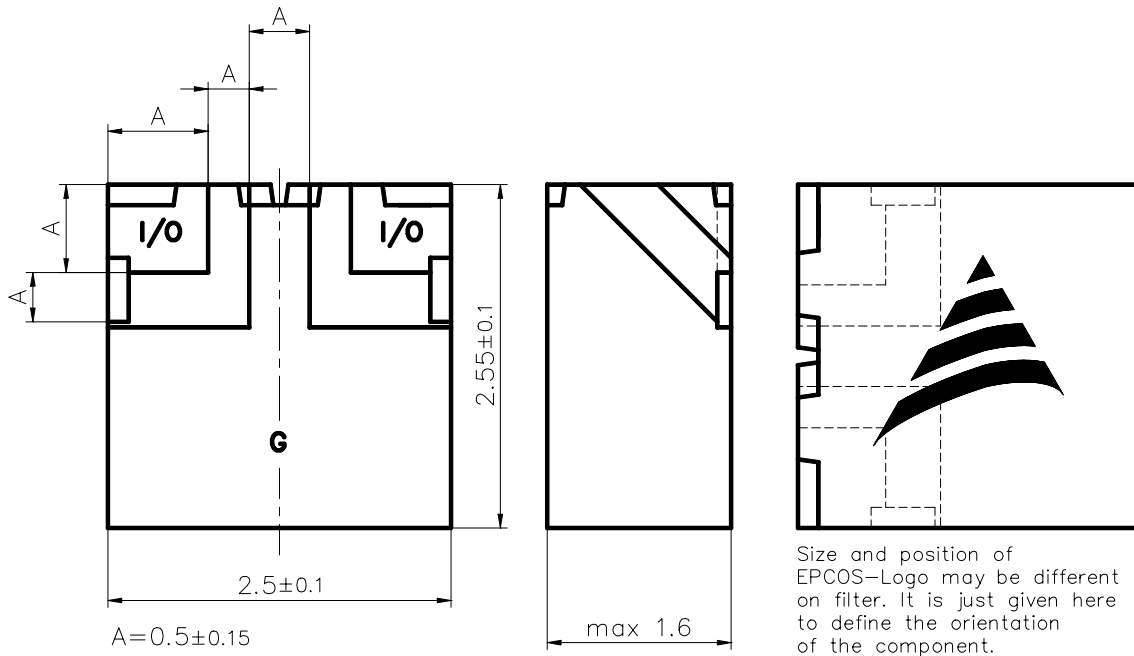

Recommended footprint

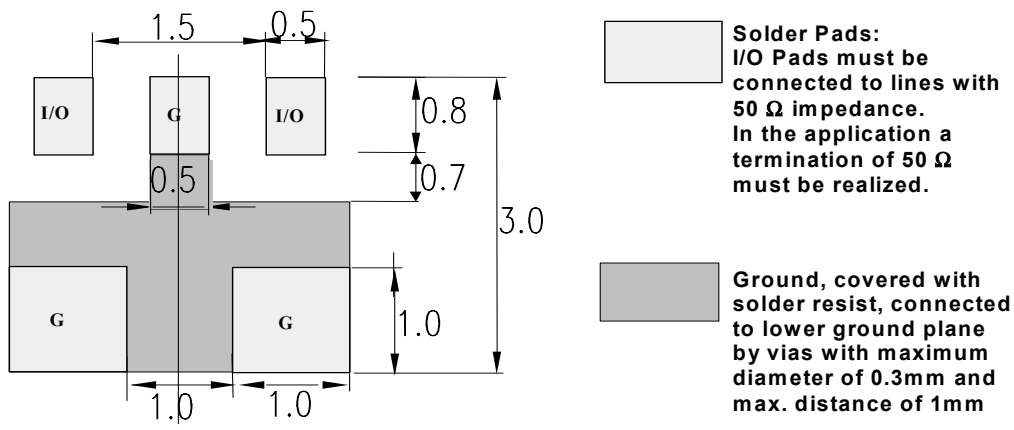

Characteristics

		min.	typ.	max.	
Center frequency	f_c	-	2.450	-	GHz
Insertion loss	α_{IL}		1.2	1.6	dB
Passband (2400- 2500)	B	100			MHz
Amplitude ripple (peak - peak)	$\Delta\alpha$		0.4	0.8	dB
Standing wave ratio	SWR		1.5	2.0	
Impedance	Z		50		Ω
Attenuation	α				
	at DC to 880 MHz	50	55		dB
	at 880 to 960 MHz	45	50		dB
	at 960 to 1990 MHz	40	45		dB
	at 1990 to 2100 MHz	25	30		dB
	at 2100 to 2170 MHz	20	25		dB
	at 3000 to 3200 MHz	15	20		dB
	at 3200 to 3500 MHz	20	25		dB
	at 3500 to 4800 MHz	27	30		dB
	at 4800 to 5000 MHz	25	30		dB

Maximum ratings

IEC climatic category (IEC 68-1)		- 40 /+ 90/56	
Operating temperature	T_{op}	- 40 / + 85	°C

Typical passband characteristic

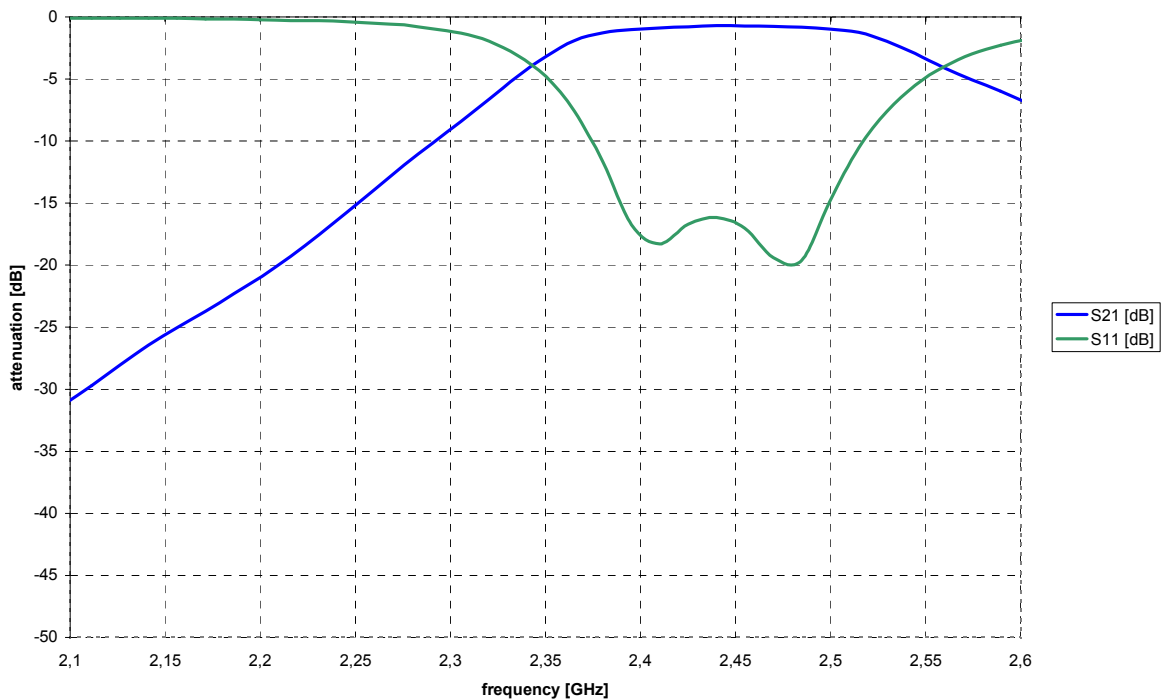

Preliminary datasheet

Processing information

- Wettability to IEC 68-2-58: $\geq 75\%$ (after aging)

Soldering Requirements

	Profile for eutectic SnPb solder paste	Profile for leadfree solder paste	
Soldering type	reflow	reflow	
Maximum soldering temperature (measuring point on top surface of the component)	235 (max. 2 sec.) 225 (max. 10 sec.)	260 (max. 2 sec.) 250 (max. 10 sec.)	$^{\circ}\text{C}$ $^{\circ}\text{C}$

Recommended soldering conditions (infrared):

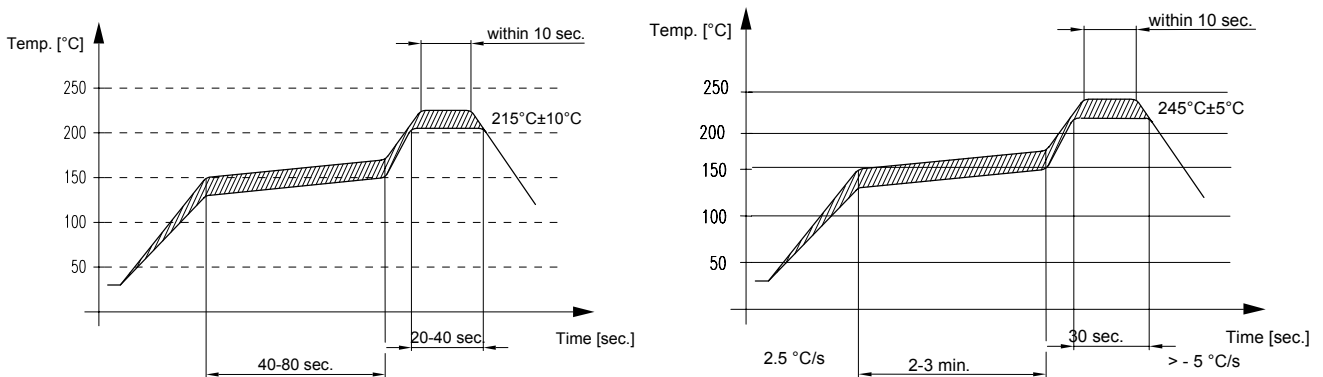

Delivery mode

- Blister tape acc. to IEC 286-3, grey
- Pieces/tape: 4000

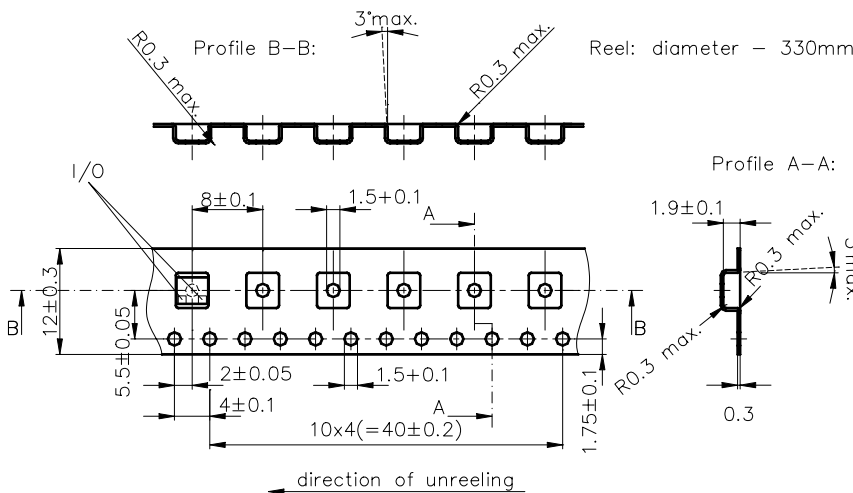

© EPCOS AG 2001. All Rights Reserved. Reproduction, publication and dissemination of this data sheet, enclosures hereto and the information contained therein without EPCOS' prior express consent is prohibited.

The information contained in this data sheet describes the type of component and shall not be considered as guaranteed characteristics. Purchase orders are subject to the General Conditions for the Supply of Products and Services of the Electrical and Electronics Industry recommended by the ZVEI (German Electrical and Electronic Manufacturers' Association), unless otherwise agreed.

ISSUE DATE	27.08.03	ISSUE	P1	PUBLISHER	SAW MWC PD F	PAGE	4/4
------------	----------	-------	----	-----------	--------------	------	-----