



SAW multimedia filters

Series/Type: K7262D

The following products presented in this data sheet are being withdrawn.

Ordering Code	Substitute Product	Date of Withdrawal	Deadline Last Orders	Last Shipments
B39380K7262N201		2011-01-14	2011-09-30	2012-09-30

For further information please contact your nearest EPCOS sales office, which will also support you in selecting a suitable substitute. The addresses of our worldwide sales network are presented at www.epcos.com/sales.



SAW Components

K 7262 D

IF Filter for Video / Multistandard Applications

38,00 MHz

Data Sheet

Standard

- B/G
- D/K
- M/N

Duroplast package **SIP5D**

Features

- TV IF filter switchable from M/N mode to B/G, D/K mode
- M/N mode with Nyquist slope and sound suppression
- Customized group delay predistortion
- B/G, D/K mode with Nyquist slope and sound suppression
- Reduced group delay predistortion as compared with standard B/G, half
- Standard IC package

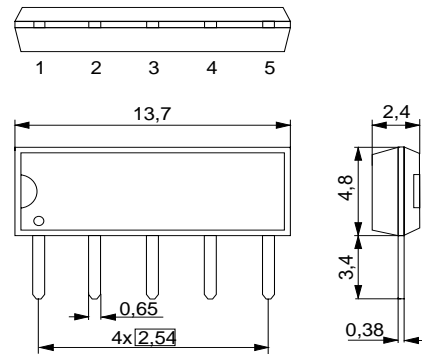

Dimensions in mm, approx. weight 0,5 g

Terminals

- Tinned CuFe alloy

Pin configuration

- 1 Input
- 2 Switching input
- 3 Chip carrier - ground
- 4 Output
- 5 Output

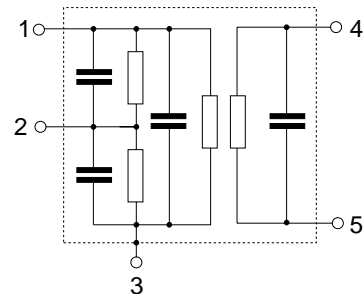

Type	Ordering code	Marking and package according to	Packing according to
K 7262 D	B39380-K7262-N201	C61157-A1-A21	F61074-V8049-Z000

Maximum ratings

Operable temperature range	T_A	-25/+65	°C	
Storage temperature range	T_{stg}	-40/+85	°C	
DC voltage	V_{DC}	5	V	between any terminals
AC voltage	V_{pp}	10	V	between any terminals

SAW Components
K 7262 D
IF Filter for Video / Multistandard Applications
38,00 MHz
Data Sheet
Characteristics in B/G, D/K mode (switching pin 2 connected to ground)

Reference temperature: $T_A = 25\text{ °C}$
 Terminating source impedance: $Z_S = 50\ \Omega$
 Terminating load impedance: $Z_L = 2\text{ k}\Omega \parallel 3\text{ pF}$

		min.	typ.	max.	
Insertion attenuation					
	α				
Reference level for the following data	36,50 MHz	14,4	15,9	17,4	dB
Relative attenuation					
	α_{rel}				
Picture carrier	38,00 MHz	4,7	5,7	6,7	dB
Color carrier	33,57 MHz	0,8	1,8	2,8	dB
Sound carrier	32,50 MHz	35,0	44,0	—	dB
	32,55 MHz	—	40,0	—	dB
	32,00 MHz	35,0	41,0	—	dB
	31,50 MHz	45,0	53,0	—	dB
Adjacent picture carrier	30,00 MHz	44,0	53,0	—	dB
	31,00 MHz	43,0	49,0	—	dB
Adjacent sound carrier	39,50 MHz	44,0	53,0	—	dB
	40,00 MHz	44,0	56,0	—	dB
	40,50 MHz	—	48,0	—	dB
Lower sidelobe	25,00 ... 30,00 MHz	44,0	52,0	—	dB
Upper sidelobe	39,50 ... 45,00 MHz	39,0	44,0	—	dB
Reflected wave signal suppression					
1,2 μ s ... 6,0 μ s after main pulse (test pulse 250 ns, carrier frequency 36,50 MHz)		42,0	52,0	—	dB
Feedthrough signal suppression					
1,2 μ s ... 1,1 μ s before main pulse (test pulse 250 ns, carrier frequency 36,50 MHz)		—	56,0	—	dB
Group delay predistortion					
(reference frequency 38,00 MHz)					
	$\Delta\tau$				
	36,00 MHz	—	-50	—	ns
	33,57 MHz	—	70	—	ns
Impedance at 36,50 MHz					
Input: $Z_{IN} = R_{IN} \parallel C_{IN}$		—	1,2 \parallel 18,6	—	k Ω \parallel pF
Output: $Z_{OUT} = R_{OUT} \parallel C_{OUT}$		—	1,7 \parallel 4,7	—	k Ω \parallel pF
Temperature coefficient of frequency					
	TC_f	—	-72	—	ppm/K

SAW Components
K 7262 D
IF Filter for Video / Multistandard Applications
38,00 MHz
Data Sheet
Characteristics in M/N mode (switching pin 2 connected to pin 1)

Reference temperature: $T_A = 25\text{ °C}$
 Terminating source impedance: $Z_S = 50\ \Omega$
 Terminating load impedance: $Z_L = 2\text{ k}\Omega \parallel 3\text{ pF}$

		min.	typ.	max.	
Insertion attenuation					
	α				
Reference level for the following data	36,50 MHz	14,5	16,0	17,5	dB
Relative attenuation					
	α_{rel}				
Picture carrier	38,00 MHz	4,8	5,8	6,8	dB
Color carrier	34,42 MHz	0,9	1,9	2,9	dB
Sound carrier	33,50 MHz	30,0	47,0	—	dB
Adjacent picture carrier	32,00 MHz	47,0	60,0	—	dB
Adjacent sound carrier	39,50 MHz	43,0	51,0	—	dB
Lower sidelobe	25,00 ... 32,00 MHz	41,0	48,0	—	dB
Upper sidelobe	39,50 ... 45,00 MHz	37,0	43,0	—	dB
Reflected wave signal suppression					
1,3 μ s ... 6,0 μ s after main pulse (test pulse 250 ns, carrier frequency 36,50 MHz)		42,0	52,0	—	dB
Feedthrough signal suppression					
1,2 μ s ... 1,1 μ s before main pulse (test pulse 250 ns, carrier frequency 36,50 MHz)		—	56,0	—	dB
Group delay predistortion					
(reference frequency 38,00 MHz)					
	$\Delta\tau$				
	35,00 MHz	—	20	—	ns
	34,42 MHz	—	70	—	ns
Impedance at 36,50 MHz					
	Input: $Z_{IN} = R_{IN} \parallel C_{IN}$	—	1,3 \parallel 15,5	—	k Ω \parallel pF
	Output: $Z_{OUT} = R_{OUT} \parallel C_{OUT}$	—	1,7 \parallel 4,7	—	k Ω \parallel pF
Temperature coefficient of frequency					
	TC_f	—	-72	—	ppm/K



Data Sheet

Frequency response in B/G, D/K mode

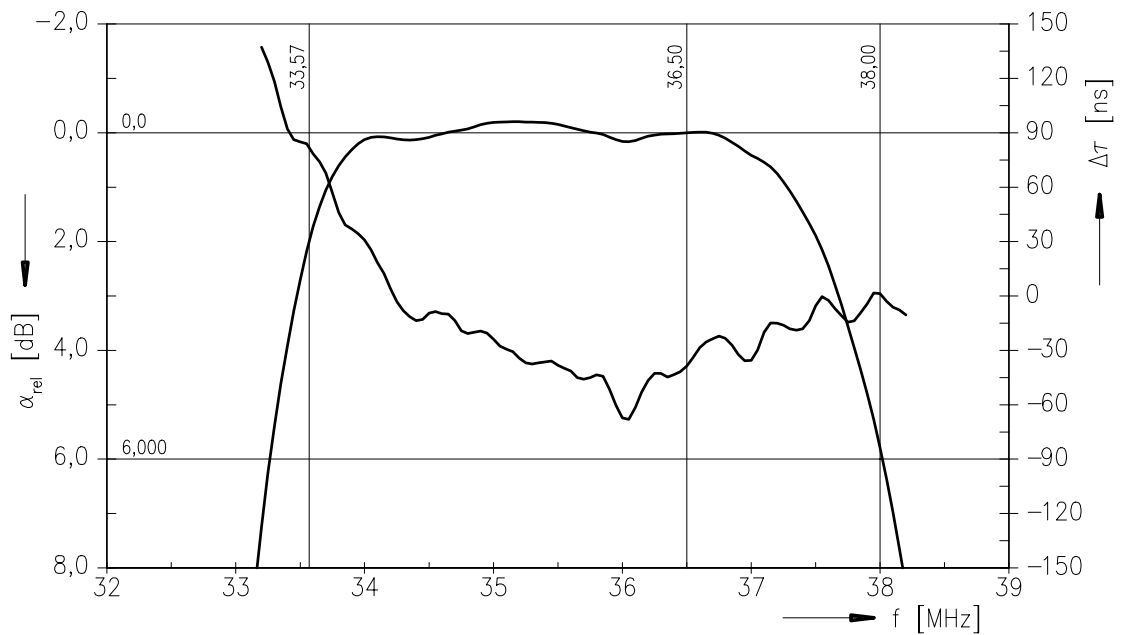
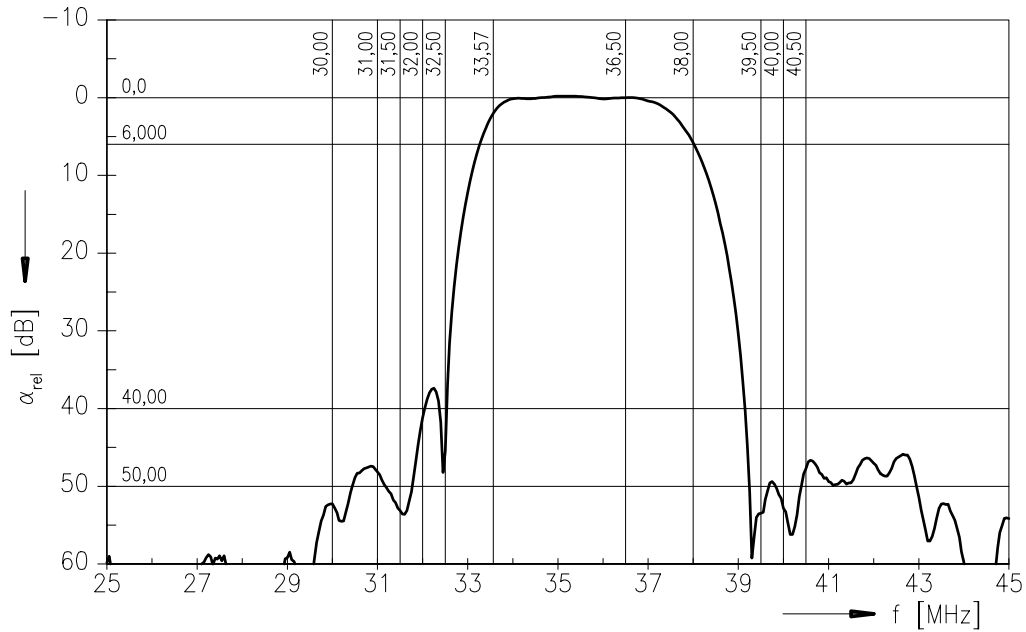



SAW Components

K 7262 D

IF Filter for Video / Multistandard Applications

38,00 MHz

Data Sheet

Frequency response B/G, D/K mode

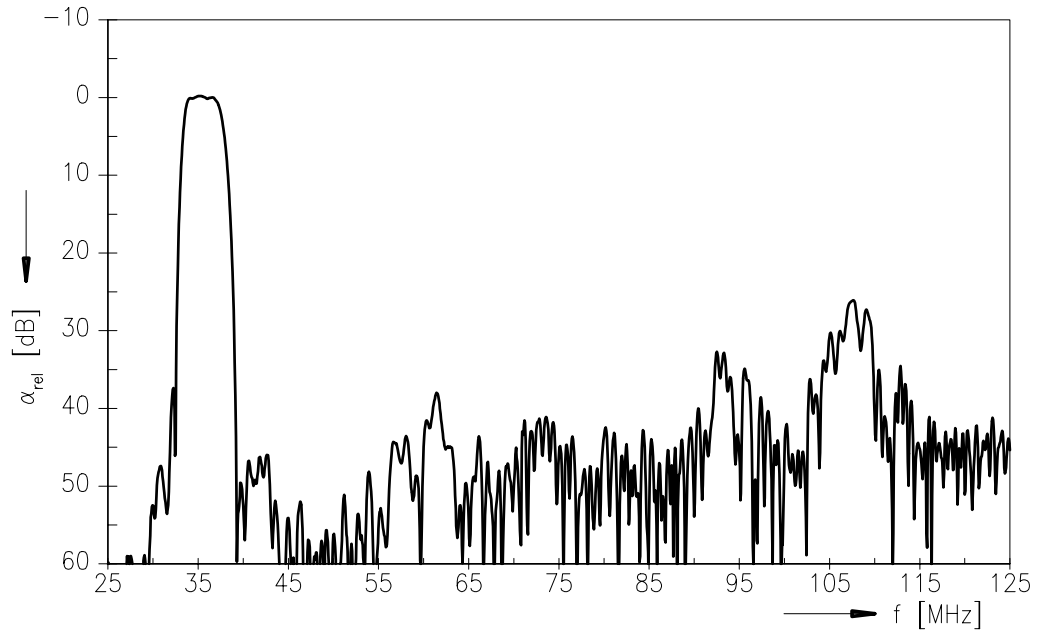

Time domain response B/G, D/K mode

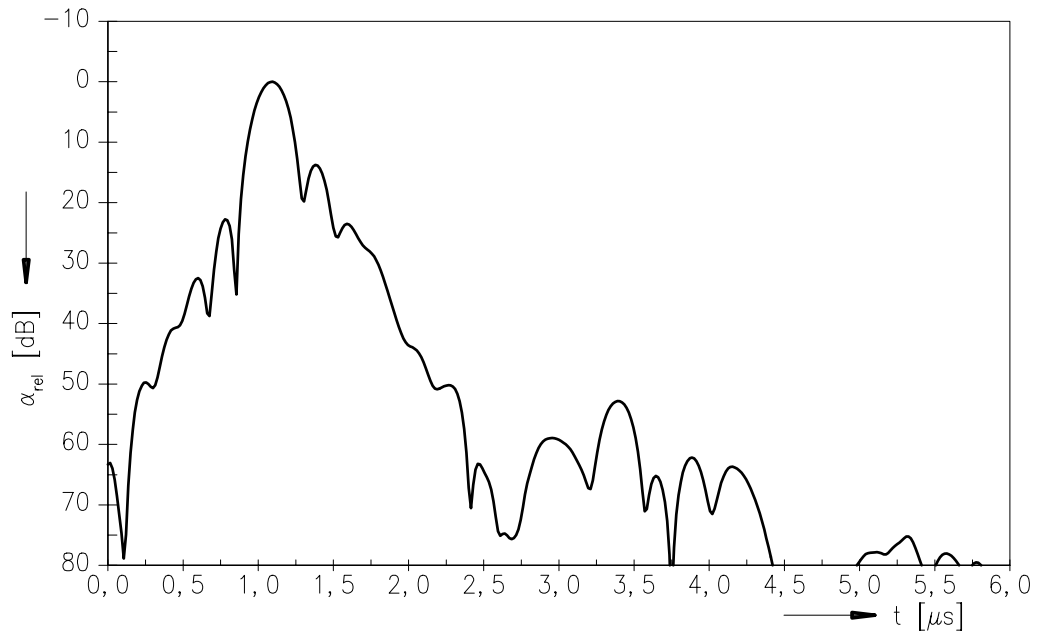



Data Sheet

Frequency response in M/N mode

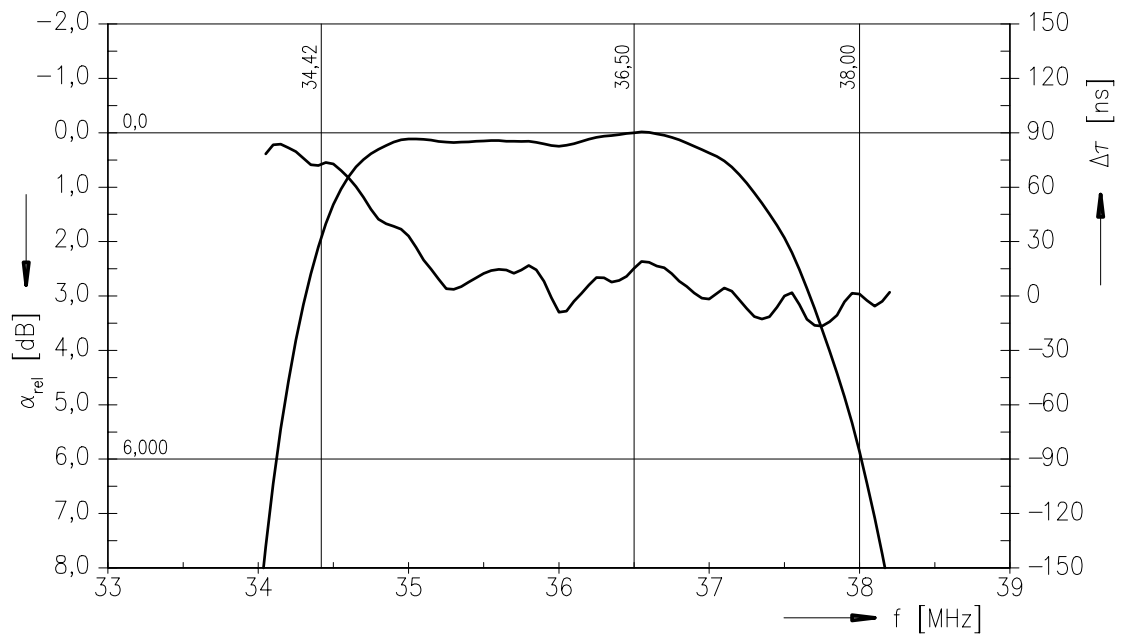
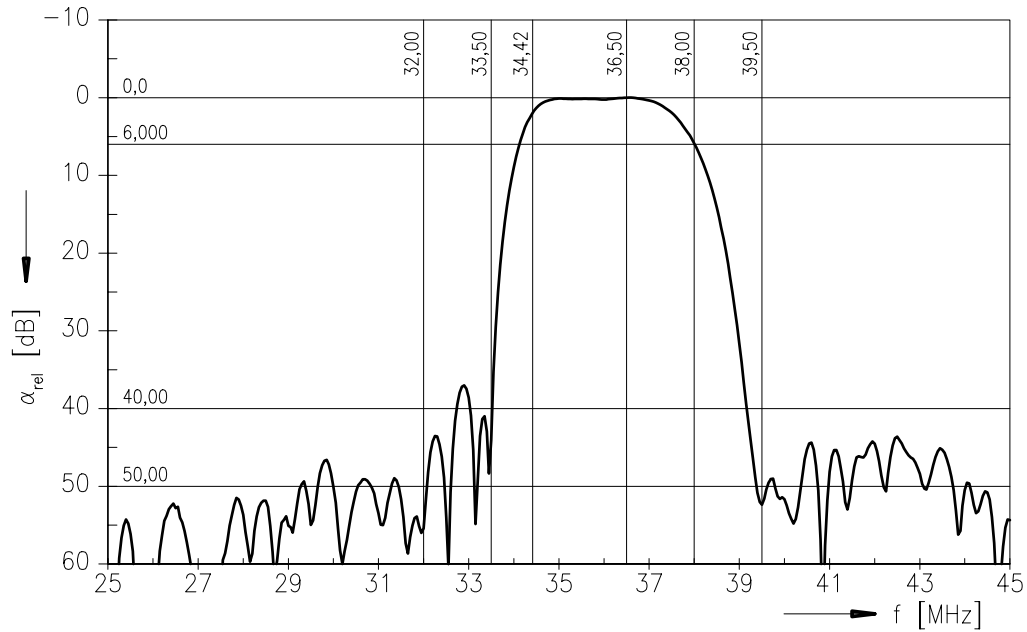



Data Sheet

Frequency response M/N mode

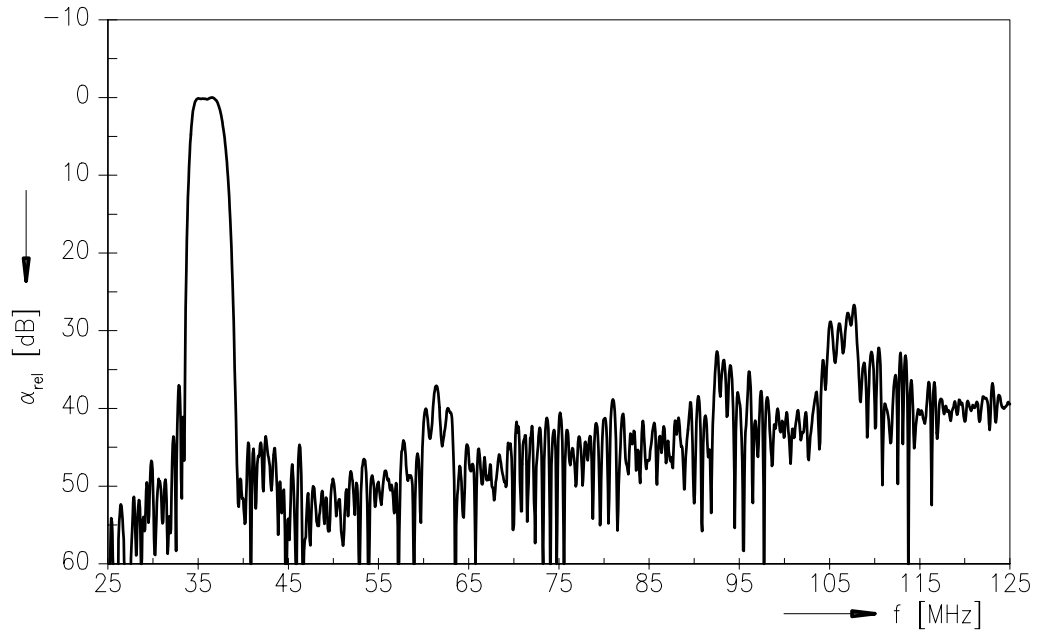

Time domain response M/N mode

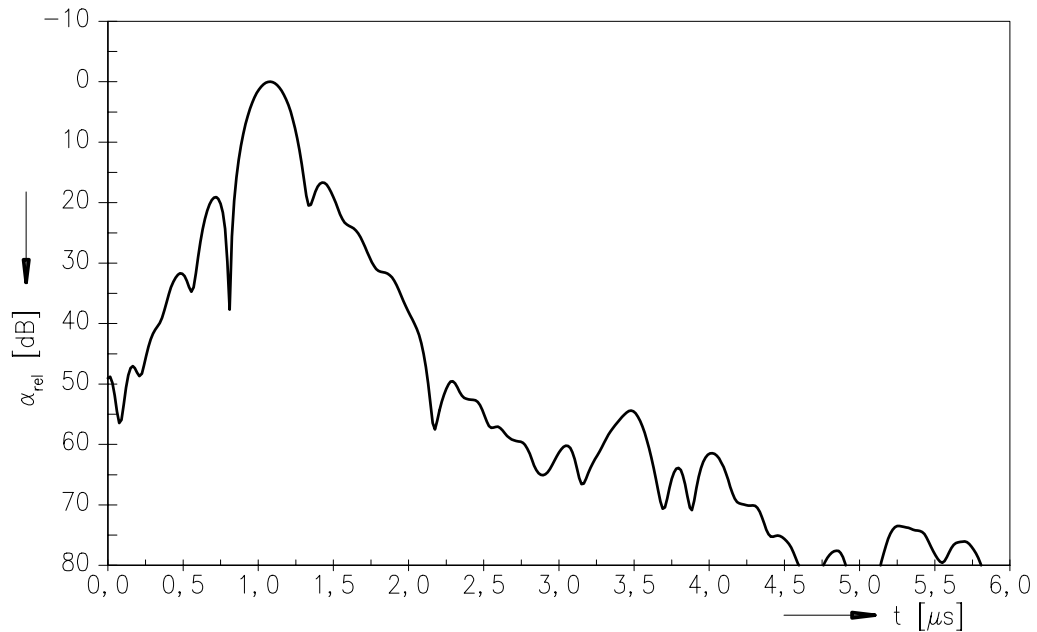



SAW Components

K 7262 D

IF Filter for Video / Multistandard Applications

38,00 MHz

Data Sheet

Published by EPCOS AG

Surface Acoustic Wave Components Division, SAW CE MM PD

P.O. Box 80 17 09, 81617 Munich, GERMANY

© EPCOS AG 2003. Reproduction, publication and dissemination of this brochure and the information contained therein without EPCOS' prior express consent is prohibited.

Purchase orders are subject to the General Conditions for the Supply of Products and Services of the Electrical and Electronics Industry recommended by the ZVEI (German Electrical and Electronic Manufacturers' Association), unless otherwise agreed.

This brochure replaces the previous edition.

For questions on technology, prices and delivery please contact the Sales Offices of EPCOS AG or the international Representatives.

Due to technical requirements components may contain dangerous substances. For information on the type in question please also contact one of our Sales Offices.