

Data Sheet

Module pinning and size

Package MC240B

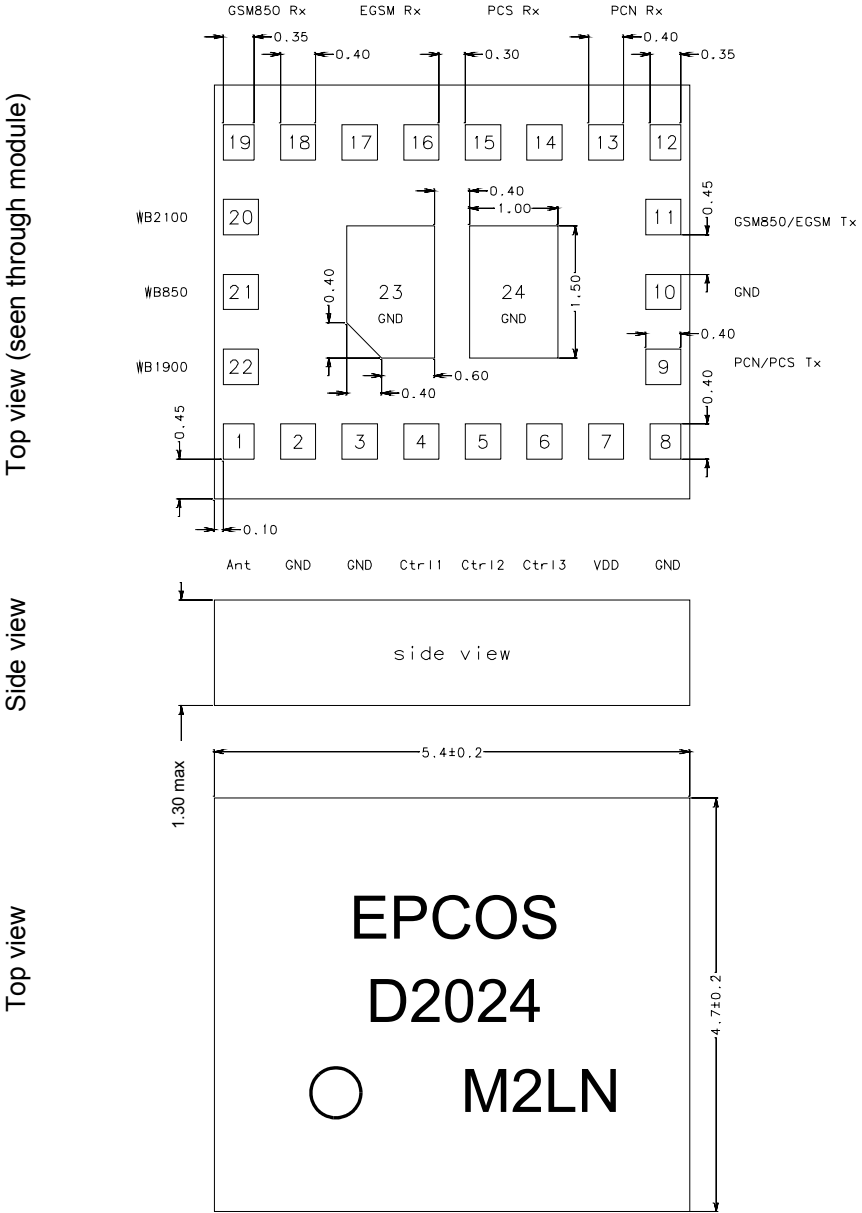

Data Sheet

Block diagram

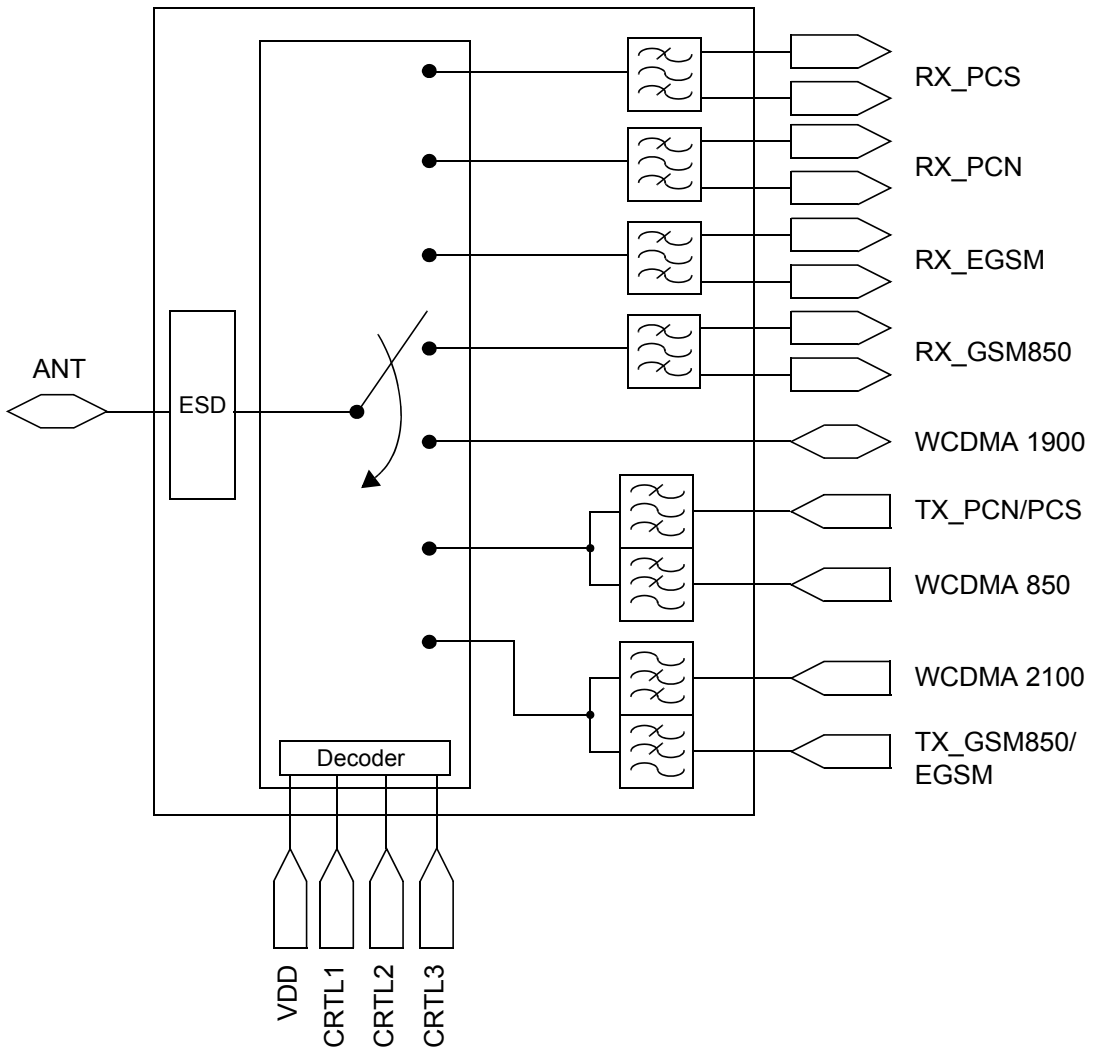

Data Sheet
Characteristics GSM850/EGSM TX

Operating temperature range:	T = -30 ... +85 °C
Terminating source impedance:	Z _I = 50 Ω
Terminating load impedance:	Z _O = 50 Ω

		D2024			
		min.	typ. 25 °C	max.	
Passband frequency	f _{TX}	824		849	
Insertion loss	IL _{TX}	—	1.45	1.7	dB
Amplitude ripple		—	0.05	0.4	dB
VSWR Antenna	VSWR	—	1.35	1.5	
VSWR Tx	VSWR	—	1.35	1.5	
Passband frequency	f _{TX}	880		915	
Insertion loss	IL _{TX}	—	1.45	1.7	dB
Amplitude ripple		—	0.1	0.4	dB
VSWR Antenna	VSWR	—	1.3	1.5	
VSWR Tx	VSWR	—	1.3	1.5	
Attenuation					
2f _{TX}	1648 ... 1698 MHz	30	32	—	dB
	1760 ... 1830 MHz	29	31	—	dB
3f _{TX}	2472 ... 2547 MHz	25	37	—	dB
	2640 ... 2745 MHz	25	30	—	dB
4f _{TX}	3296 ... 3396 MHz	23	38	—	dB
	3520 ... 3660 MHz	23	38	—	dB
Isolation					
GSM850/EGSM Tx -> GSM850 Rx	824 ... 915 MHz	30	48	—	dB
GSM850/EGSM Tx -> EGSM Rx	824 ... 915 MHz	35	60	—	dB
GSM850/EGSM Tx -> PCN Rx	824 ... 915 MHz	35	50	—	dB
	1805 ... 1880 MHz	28	32	—	dB
GSM850/EGSM Tx -> PCS Rx	824 ... 915 MHz	35	55	—	dB
GSM850/EGSM Tx -> WCDMA850	824 ... 915 MHz	23	35	—	dB
GSM850/EGSM Tx -> WCDMA1900	824 ... 915 MHz	23	34	—	dB
GSM850/EGSM Tx -> WCDMA2100	824 ... 915 MHz	23	30	—	dB
PCN/PCS Tx -> Ant	1648 ... 1830 MHz	20	26	—	dB
	2472 ... 2745 MHz	15	20	—	dB
WCDMA2100 -> WCDMA1900	1930 ... 1980 MHz	23	29	—	dB

Data Sheet

	D2024			
	min.	typ. 25 °C	max.	
Harmonic generation $P_{IN} = 35$ dBm antenna port: VSWR Ant 1:1				
$2 \cdot f_{TX}$	—	-50	-38	dBm
$3 \cdot f_{TX}$	—	-45	-38	dBm
$4 \dots 12 \cdot f_{TX}$	—	-70	-38	dBm
Harmonic generation antenna port: VSWR Ant 3:1, $P_{MAX} = 33$ dBm				
$2 \cdot f_{TX}$	—	-50	-30	dBm
$3 \cdot f_{TX}$	—	-45	-30	dBm

Data Sheet
Characteristics PCN/PCS TX

Operating temperature range: $T = -30 \dots +85 \text{ }^\circ\text{C}$
Terminating source impedance: $Z_I = 50 \text{ } \Omega$
Terminating load impedance: $Z_O = 50 \text{ } \Omega$

				D2024			
				min.	typ. 25 °C	max.	
Passband frequency			f_{Tx}	1710		1785	
Insertion loss			IL_{Tx}	—	1.6	1.8	dB
Amplitude ripple				—	0.1	0.4	dB
VSWR Antenna			VSWR	—	1.1	1.5	
VSWR Tx			VSWR	—	1.2	1.5	
Passband frequency			f_{Tx}	1850		1910	
Insertion loss			IL_{Tx}	—	1.6	1.8	dB
Amplitude ripple				—	0.1	0.4	dB
VSWR Antenna			VSWR	—	1.1	1.5	
VSWR Tx			VSWR	—	1.2	1.5	
Attenuation							
$2f_{Tx}$	3420 ... 3570		MHz	30	33	—	dB
	3700 ... 3820		MHz	29	31	—	dB
$3f_{Tx}$	5130 ... 5355		MHz	30	40	—	dB
	5550 ... 5730		MHz	30	45	—	dB
Isolation							
PCN/PCS Tx -> GSM850 Rx	1710 ... 1910		MHz	40	60	—	dB
PCN/PCS Tx -> EGSM Rx	1710 ... 1910		MHz	40	65	—	dB
PCN/PCS Tx -> PCN Rx	1710 ... 1910		MHz	30	38	—	dB
PCN/PCS Tx -> PCS Rx	1710 ... 1910		MHz	35	55	—	dB
PCN/PCS Tx -> WCDMA850	1710 ... 1910		MHz	18	20	—	dB
PCN/PCS Tx -> WCDMA1900	1710 ... 1910		MHz	20	29	—	dB
PCN/PCS Tx -> WCDMA2100	1710 ... 1910		MHz	20	31	—	dB
WCDMA850-> PCN/PCS Tx	824 ... 849		MHz	27	29	—	dB
GSM850/EGSM Tx -> Ant	3420 ... 3820		MHz	20	48	—	dB
	5130 ... 5730		MHz	20	48	—	dB

Data Sheet

	D2024			
	min.	typ. 25 °C	max.	
Harmonic generation $P_{IN} = 33$ dBm antenna port: VSWR Ant 1:1				
$2 \cdot f_{TX}$	—	-50	-38	dBm
$3 \cdot f_{TX}$	—	-50	-38	dBm
$4 \dots 7 \cdot f_{TX}$	—	-70	-38	dBm
Harmonic generation antenna port: VSWR Ant 3:1, $P_{MAX} = 31$ dBm				
$2 \cdot f_{TX}$	—	-48	-30	dBm
$3 \cdot f_{TX}$	—	-48	-30	dBm

Data Sheet
Characteristics WCDMA850

Operating temperature range:	$T = -30 \dots +85 \text{ }^\circ\text{C}$
Terminating source impedance:	$Z_I = 50 \text{ } \Omega$
Terminating load impedance:	$Z_O = 50 \text{ } \Omega$

			D2024			
			min.	typ. 25 °C	max.	
Passband frequency		f_{Tx}	824		849	
Insertion loss	@25 °C	IL_{Tx}	—	1.15	1.4	dB
Insertion loss					1.5	dB
Amplitude ripple			—	0.1	0.4	dB
VSWR Antenna		VSWR	—	1.1	1.5	
VSWR Tx		VSWR	—	1.1	1.5	
Passband frequency		f_{Rx}	869		894	
Insertion loss	@25 °C	IL_{Rx}	—	1.2	1.4	dB
Insertion loss					1.5	dB
Amplitude ripple			—	0.1	0.4	dB
VSWR Antenna		VSWR	—	1.1	1.5	
VSWR Tx		VSWR	—	1.1	1.5	
Intermodulation						
$P_{IM3-WCDMA850-Rx}$	at 869 ... 894 MHz	P_{IM3}	—	-107	-100	dBm
P_{WCDMA}	= +20 dBm at 824 ... 849 MHz					
P_{CW-Ant}	= -15 dBm at 779 ... 804 MHz					
at worst case phase angle at WCDMA port						
$P_{IM2-WCDMA850-Rx}$	at 869 ... 894 MHz	P_{IM2}	—	-112	-100	dBm
P_{WCDMA}	= +20 dBm at 824 ... 849 MHz					
P_{CW-Ant}	= -15 dBm at 1693 ... 1743 MHz					
P_{CW-Ant}	= -15 dBm at 45 MHz					
at worst case phase angle at WCDMA port						
Harmonic generation $P_{IN} = 27 \text{ dBm}$						
	$2 \cdot f_{Tx}$		—	-64	-40	dBm
	$3 \cdot f_{Tx}$		—	-66	-40	dBm
	$4 \dots 7 \cdot f_{Tx}$		—	-70	-40	dBm

Data Sheet
Characteristics WCDMA1900

Operating temperature range:	$T = -30 \dots +85 \text{ }^\circ\text{C}$
Terminating source impedance:	$Z_I = 50 \text{ } \Omega$
Terminating load impedance:	$Z_O = 50 \text{ } \Omega$

		D2024				
		min.	typ. @25 °C	max.		
Passband frequency	f_{Tx}	1850		1910		
Insertion loss	@25 °C IL_{Tx}	—	0.95	1.2	dB	
Insertion loss				1.3	dB	
Amplitude ripple		—	0.1	0.4	dB	
VSWR Antenna	VSWR	—	1.2	1.5		
VSWR Tx	VSWR	—	1.2	1.5		
Passband frequency	f_{Rx}	1930		1990		
Insertion loss	@25 °C IL_{Rx}	—	0.95	1.2	dB	
Insertion loss				1.3	dB	
Amplitude ripple		—	0.1	0.4	dB	
VSWR Antenna	VSWR	—	1.2	1.5		
VSWR Tx	VSWR	—	1.2	1.5		
Isolation						
WCDMA2100 -> WCDMA1900 1930 ... 1990 MHz		20	25	—	dB	
WCDMA1900 -> PCN Rx 1850 ... 1880 MHz		23	38	—	dB	
Intermodulation						
$P_{IM3-WCDMA1900-Rx}$ at 1930 ... 1990 MHz $P_{WCDMA} = +20 \text{ dBm}$ at 1850 ... 1910 MHz $P_{CW-Ant} = -15 \text{ dBm}$ at 1770 ... 1830 MHz at worst case phase angle at WCDMA port		P_{IM3}	—	-110	-100	dBm
$P_{IM2-WCDMA1900-Rx}$ at 1930 ... 1990 MHz $P_{WCDMA} = +20 \text{ dBm}$ at 1850 ... 1910 MHz $P_{CW-Ant} = -15 \text{ dBm}$ at 80 MHz at worst case phase angle at WCDMA port		P_{IM2}	—	-115	-100	dBm
Harmonic generation $P_{IN} = 27 \text{ dBm}$						
$2 \cdot f_{Tx}$		—	-57	-40	dBm	
$3 \cdot f_{Tx}$		—	-68	-40	dBm	
$4 \dots 7 \cdot f_{Tx}$		—	-70	-40	dBm	

Data Sheet
Characteristics WCDMA1900 port at WCDMA2100 frequencies

Operating temperature range:	$T = -30 \dots +85 \text{ }^\circ\text{C}$
Terminating source impedance:	$Z_I = 50 \ \Omega$
Terminating load impedance:	$Z_O = 50 \ \Omega$

			D2024			
			min.	typ. 25 °C	max.	
Passband frequency		f_{Tx}	1920		1980	
Insertion loss	@ 25 °C	IL_{Tx}	—	1.0	1.3	dB
Insertion loss					1.4	dB
Amplitude ripple			—	0.1	0.4	dB
VSWR Antenna		VSWR	—	1.2	1.5	
VSWR Tx		VSWR	—	1.2	1.5	
Passband frequency		f_{Rx}	2110		2170	
Insertion loss	@ 25 °C	IL_{Rx}	—	1.0	1.3	dB
Insertion loss					1.4	dB
Amplitude ripple			—	0.1	0.4	dB
VSWR Antenna		VSWR	—	1.2	1.5	
VSWR Tx		VSWR	—	1.2	1.5	
Intermodulation						
$P_{IM3-WCDMA2100-Rx}$ at 2110 ... 2170 MHz		P_{IM3}	—	-110	-100	dBm
$P_{WCDMA} = +20$ dBm at 1920 ... 1980 MHz						
$P_{CW-Ant} = -15$ dBm at 1730 ... 1790 MHz						
at worst case phase angle at WCDMA port						
$P_{IM2-WCDMA2100-Rx}$ at 2110 ... 2170 MHz		P_{IM2}	—	-115	-100	dBm
$P_{WCDMA} = +20$ dBm at 1920 ... 1980 MHz						
$P_{CW-Ant} = -15$ dBm at 190 MHz						
at worst case phase angle at WCDMA port						
Harmonic generation $P_{IN} = 27$ dBm						
$2 \cdot f_{Tx}$			—	-57	-40	dBm
$3 \cdot f_{Tx}$			—	-68	-40	dBm
$4 \dots 7 \cdot f_{Tx}$			—	-70	-40	dBm

Data Sheet
Characteristics WCDMA2100

Operating temperature range:	$T = -30 \dots +85^{\circ}\text{C}$
Terminating source impedance:	$Z_I = 50 \Omega$
Terminating load impedance:	$Z_O = 50 \Omega$

			D2024			
			min.	typ. 25 °C	max.	
Passband frequency		f_{Tx}	1920		1980	
Insertion loss	@25 °C	IL_{Tx}	—	1.5	1.7	dB
Insertion loss					1.75	dB
Amplitude ripple			—	0.1	0.4	dB
VSWR Antenna		VSWR	—	1.25	1.5	
VSWR Tx		VSWR	—	1.2	1.5	
Passband frequency		f_{Rx}	2110		2170	
Insertion loss	@25 °C	IL_{Rx}	—	1.6	1.8	dB
Insertion loss					1.85	dB
Amplitude ripple			—	0.1	0.4	dB
VSWR Antenna		VSWR	—	1.25	1.5	
VSWR Tx		VSWR	—	1.3	1.5	
Intermodulation						
$P_{IM3-WCDMA2100-Rx}$ at 2110 ... 2170 MHz $P_{WCDMA} = +20$ dBm at 1920 ... 1980 MHz $P_{CW-Ant} = -15$ dBm at 1730 ... 1790 MHz at worst case phase angle at WCDMA port		P_{IM3}	—	-110	-100	dBm
$P_{IM2-WCDMA2100-Rx}$ at 2110 ... 2170 MHz $P_{WCDMA} = +20$ dBm at 1920 ... 1980 MHz $P_{CW-Ant} = -15$ dBm at 190 MHz at worst case phase angle at WCDMA port		P_{IM2}	—	-115	-100	dBm
Harmonic generation $P_{IN} = 27$ dBm						
$2 \cdot f_{Tx}$			—	-70	-40	dBm
$3 \cdot f_{Tx}$			—	-70	-40	dBm
$4 \dots 7 \cdot f_{Tx}$			—	-70	-40	dBm

Data Sheet

Characteristics GSM850 RX

Operating temperature range: $T = -30 \dots +85 \text{ }^\circ\text{C}$
 Terminating source impedance: $Z_I = 50 \text{ } \Omega$
 Terminating load impedance: $Z_O = 150 \text{ } \Omega \parallel 47 \text{ nH}$

				D2024			
				min.	typ. @25 °C	max.	
Passband frequency			f_{Rx}	869		894	
Insertion loss		@25 °C	IL_{Rx}	—	2.15	3.3	dB
Insertion loss		@ -10 °C ... +85 °C		—	2.5	3.6	dB
Insertion loss		@ -30 °C ... +85 °C		—	2.6	3.6	dB
Amplitude ripple				—	1.0	1.5	dB
Amplitude imbalance	(S_{31}/S_{21})			—	± 0.5	± 1.5	dB
Phase imbalance	$\phi(S_{31}) - \phi(S_{21}) - 180^\circ$			—	± 6	± 10	deg
VSWR Antenna			VSWR	—	1.6	2.3	
VSWR Rx			VSWR	—	1.6	2.3	
Attenuation	0 ... 824 MHz			30	35	—	dB
	824 ... 849 MHz			30	40	—	dB
	914 ... 1000 MHz			23	30	—	dB
	1000 ... 1738 MHz			30	36	—	dB
	1738 ... 1788 MHz			35	45	—	dB
	1788 ... 2400 MHz			30	45	—	dB
	2400 ... 2500 MHz			35	48	—	dB
	2500 ... 2607 MHz			30	48	—	dB
	2607 ... 2682 MHz			35	42	—	dB
	2682 ... 4345 MHz			30	44	—	dB
	4345 ... 4470 MHz			35	44	—	dB
	4470 ... 6000 MHz			30	44	—	dB
Isolation							
GSM850/EGSM Tx -> Ant	824 ... 849 MHz			20	38	—	dB

Data Sheet

Characteristics EGSM RX

Operating temperature range: $T = -30 \dots +85 \text{ }^\circ\text{C}$
 Terminating source impedance: $Z_I = 50 \text{ } \Omega$
 Terminating load impedance: $Z_O = 150 \text{ } \Omega \parallel 47 \text{ nH}$

				D2024			
				min.	typ. @25 °C	max.	
Passband frequency			f_{RX}	925		960	
Insertion loss		@25 °C	IL_{RX}	—	2.55	3.3	dB
Insertion loss		@ -10 °C ... +85 °C		—	2.9	3.6	dB
Insertion loss		@ -30 °C ... +85 °C		—	3.0	3.6	dB
Amplitude ripple				—	1.0	1.5	dB
Amplitude imbalance	(S_{31}/S_{21})			—	± 0.7	± 1.5	dB
Phase imbalance	$\phi(S_{31}) - \phi(S_{21}) - 180^\circ$			—	± 3	± 10	deg
VSWR Antenna			VSWR	—	1.7	2.3	
VSWR Rx			VSWR	—	1.8	2.3	
Attenuation	0 ...	880 MHz		30	35	—	dB
	880 ...	905 MHz		30	34	—	dB
	905 ...	915 MHz		18	28	—	dB
	980 ...	1020 MHz		25	31	—	dB
	1020 ...	1850 MHz		30	36	—	dB
	1850 ...	1920 MHz		35	45	—	dB
	1920 ...	2400 MHz		30	45	—	dB
	2400 ...	2500 MHz		35	44	—	dB
	2500 ...	2775 MHz		30	43	—	dB
	2775 ...	2880 MHz		35	45	—	dB
	2880 ...	4625 MHz		30	45	—	dB
	4625 ...	4800 MHz		40	46	—	dB
	4800 ...	6000 MHz		30	46	—	dB
Isolation							
GSM850/EGSM Tx -> Ant	880 ...	915 MHz		20	35	—	dB

Data Sheet
Characteristics PCN RX

Operating temperature range:	$T = -30 \dots +85 \text{ °C}$
Terminating source impedance:	$Z_I = 50 \text{ } \Omega$
Terminating load impedance:	$Z_O = 180 \text{ } \Omega \parallel 15 \text{ nH}$

				D2024			
				min.	typ. @25 °C	max.	
Passband frequency			f_{Rx}	1805		1880	
Insertion loss		@25 °C	IL_{Rx}	—	3.0	3.6	dB
Insertion loss		@ -10 °C ... +85 °C			3.3	3.8	dB
Insertion loss		@ -30 °C ... +85 °C			3.5	4.1	dB
Amplitude ripple				—	1.0	1.5	dB
Amplitude imbalance	(S_{31}/S_{21})			—	± 0.8	± 1.5	dB
Phase imbalance	$\phi(S_{31}) - \phi(S_{21}) - 180^\circ$			—	± 5	± 10	deg
VSWR Antenna			VSWR	—	1.8	2.3	
VSWR Rx			VSWR	—	1.7	2.3	
Attenuation	0 ... 1705 MHz			30	38	—	dB
	1705 ... 1785 MHz			12	18	—	dB
	1920 ... 1980 MHz			14	21	—	dB
	1980 ... 2100 MHz			23	30	—	dB
	2100 ... 2400 MHz			30	35	—	dB
	2400 ... 2500 MHz			30	35	—	dB
	2500 ... 3610 MHz			30	34	—	dB
	3610 ... 3760 MHz			40	55	—	dB
	3760 ... 5415 MHz			30	55	—	dB
	5415 ... 5640 MHz			40	60	—	dB
	5640 ... 6000 MHz			30	55	—	dB
Isolation							
PCN/PCS Tx -> Ant	1710 ... 1785 MHz			20	23	—	dB

Data Sheet
Characteristics PCS RX

Operating temperature range:	$T = -30 \dots +85 \text{ °C}$
Terminating source impedance:	$Z_I = 50 \text{ } \Omega$
Terminating load impedance:	$Z_O = 180 \text{ } \Omega \parallel 12 \text{ nH}$

				D2024			
				min.	typ. @25 °C	max.	
Passband frequency			f_{Rx}	1930		1990	
Insertion loss		@25 °C	IL_{Rx}	—	2.8	3.6	dB
Insertion loss		@ -10 °C ... +85 °C			3.3	3.8	dB
Insertion loss		@ -30 °C ... +85 °C			3.5	4.1	dB
Amplitude ripple				—	1.0	1.5	dB
Amplitude imbalance	(S_{31}/S_{21})			—	± 0.7	± 1.5	dB
Phase imbalance	$\phi(S_{31}) - \phi(S_{21}) - 180^\circ$			—	± 4	± 10	deg
VSWR Antenna			VSWR	—	1.5	2.3	
VSWR Rx			VSWR	—	1.5	2.3	
Attenuation	0 ... 1830 MHz			30	38	—	dB
	1830 ... 1910 MHz			10	18	—	dB
	2010 ... 2070 MHz			10	16	—	dB
	2070 ... 2100 MHz			20	26	—	dB
	2100 ... 2400 MHz			25	30	—	dB
	2400 ... 2500 MHz			35	45	—	dB
	2500 ... 3860 MHz			30	36	—	dB
	3860 ... 3980 MHz			40	55	—	dB
	3980 ... 5790 MHz			30	54	—	dB
	5790 ... 5970 MHz			40	55	—	dB
	5970 ... 6000 MHz			30	57	—	dB
Isolation							
PCN/PCS Tx -> Ant	1850 ... 1910 MHz			20	23	—	dB

Data Sheet

Notes

Type	D2024
Ordering code	B30674-D2024-R424
Marking, package and recommended pad layout	C61157-A4-A41
Packaging	F61074-V8216-Z000
Date codes	L_1126
S-parameters	
Soldering profile	S_6001

Published by EPCOS AG

Surface Acoustic Wave Components Division, SAW MLIP MO PD

P.O. Box 80 17 09, D-81617 München

© EPCOS AG 2008. All Rights Reserved.

As far as patents or other rights of third parties are concerned, liability is only assumed for components per se, not for applications, processes and circuits implemented within components or assemblies.

The information describes the type of component and shall not be considered as assured characteristics.

Terms of delivery and rights to change design reserved.

For questions on technology, prices and delivery please contact the sales offices of EPCOS AG or the international representatives.

Due to technical requirements components may contain dangerous substances. For information on the type in question please also contact one of our sales offices.

Data Sheet

The following applies to all products named in this publication:

1. Some parts of this publication contain **statements about the suitability of our products for certain areas of application**. These statements are based on our knowledge of typical requirements that are often placed on our products in the areas of application concerned. We nevertheless expressly point out **that such statements cannot be regarded as binding statements about the suitability of our products for a particular customer application**. As a rule, EPCOS is either unfamiliar with individual customer applications or less familiar with them than the customers themselves. For these reasons, it is always ultimately incumbent on the customer to check and decide whether an EPCOS product with the properties described in the product specification is suitable for use in a particular customer application.
2. We also point out that **in individual cases, a malfunction of passive electronic components or failure before the end of their usual service life cannot be completely ruled out in the current state of the art, even if they are operated as specified**. In customer applications requiring a very high level of operational safety and especially in customer applications in which the malfunction or failure of a passive electronic component could endanger human life or health (e.g. in accident prevention or life-saving systems), it must therefore be ensured by means of suitable design of the customer application or other action taken by the customer (e.g. installation of protective circuitry or redundancy) that no injury or damage is sustained by third parties in the event of malfunction or failure of a passive electronic component.
3. The warnings, cautions and product-specific notes must be observed.
4. In order to satisfy certain technical requirements, **some of the products described in this publication may contain substances subject to restrictions in certain jurisdictions (e.g. because they are classed as “hazardous”)**. Useful information on this will be found in our Material Data Sheets on the Internet (www.epcos.com/material). Should you have any more detailed questions, please contact our sales offices.
5. We constantly strive to improve our products. Consequently, **the products described in this publication may change from time to time**. The same is true of the corresponding product specifications. Please check therefore to what extent product descriptions and specifications contained in this publication are still applicable before or when you place an order. We also **reserve the right to discontinue production and delivery of products**. Consequently, we cannot guarantee that all products named in this publication will always be available.
6. Unless otherwise agreed in individual contracts, **all orders are subject to the current version of the “General Terms of Delivery for Products and Services in the Electrical Industry” published by the German Electrical and Electronics Industry Association (ZVEI)**.
7. The trade names EPCOS, CeraDiode, CSSP, PhaseCap, PhaseMod, SIFI, SIKOREL, Silver-Cap, SIMID, SIOV, SIP5D, SIP5K, TOPcap, UltraCap, WindCap are **trademarks registered or pending** in Europe and in other countries. Further information will be found on the Internet at www.epcos.com/trademarks.