



## **SAW Components**

### **SAW Duplexer**

W-CDMA Band 5 / CDMA 800

<b>Series/type:</b>	<b>B7690</b>
<b>Ordering code:</b>	<b>B39881B7690A710</b>
<b>Date:</b>	<b>December 09, 2008</b>
<b>Version:</b>	<b>2.0</b>



**Application**

- Low-loss SAW duplexer for mobile telephone W-CDMA Band 5 / CDMA 800 systems
- Low insertion attenuation
- Low amplitude ripple
- Single ended to balanced transformation in Antenna - Rx path
- Impedance transformation 50Ω to 100Ω in Antenna - Rx path

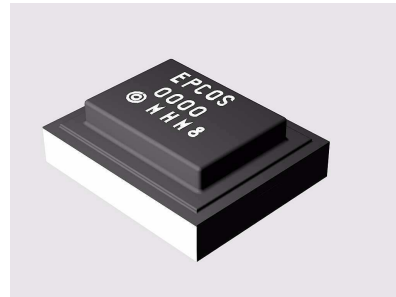

**Features**

- Package size 3.0 x 2.5 x 1.14 mm<sup>3</sup>
- RoHS compatible
- Approx. weight 0.035 g
- Package for Surface Mount Technology (SMT)
- Ni, gold-plated terminals
- Fully matched by integrated matching network
- Electrostatic Sensitive Device (ESD)

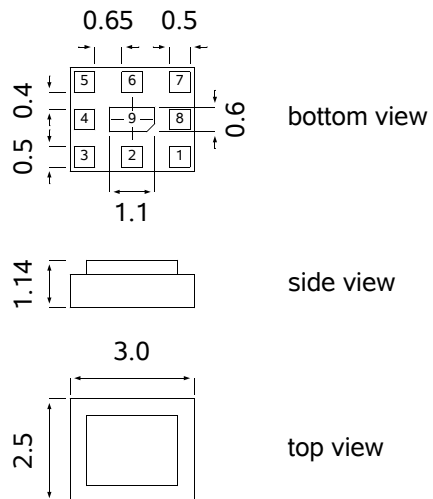

**Pin configuration**

- 1 TX Input
- 3, 4 RX Output (balanced)
- 6 Antenna
- 2, 5, 7, 8, 9 To be grounded

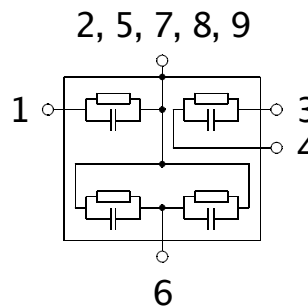



<b>SAW Components</b>	<b>B7690</b>
<b>SAW Duplexer</b>	<b>836.5 / 881.5 MHz</b>

Data Sheet



**Characteristics for W-CDMA Band 5**

Temperature range for specification:  $T = -15\text{ °C to }+80\text{ °C}$   
 Antenna terminating impedance:  $Z_{ANT} = 50\ \Omega$   
 RX terminating impedance:  $Z_{RX} = 100\ \Omega$  (balanced)  
 TX terminating impedance:  $Z_{TX} = 50\ \Omega$

Characteristics TX - ANT	min.	typ. @ 25 °C	max.	
<b>Center frequency</b> $f_c$		836.5		MHz
<b>Maximum insertion attenuation</b> @ $f_{Carrier}$ 826.4 ... 846.6 MHz $\alpha_{WCDMA}^{1)}$		1.4	1.8	dB
<b>Amplitude ripple (p-p)</b> @ $f_{Carrier}$ 826.4 ... 846.6 MHz $\Delta\alpha_{WCDMA}$		0.4	0.8	dB
<b>Error Vector Magnitude</b> @ $f_{Carrier}$ 826.4 ... 846.6 MHz EVM <sup>2)</sup>		1.4	2.5	%
<b>Input VSWR (TX port)</b> 824.0 ... 849.0 MHz		1.7	1.9	
<b>Output VSWR (ANT port)</b> 824.0 ... 849.0 MHz		1.6	1.8	

1) Attenuation of W-CDMA signal (power transfer function). Please refer to annotation on page (11).  
 2) Error Vector Magnitude (EVM) based on definition given in 3GPP TS 25.141.



<b>SAW Components</b>	<b>B7690</b>
<b>SAW Duplexer</b>	<b>836.5 / 881.5 MHz</b>

Data Sheet



**Characteristics for W-CDMA Band 5**

Temperature range for specification:	T = -15 °C to +80 °C
Antenna terminating impedance:	Z <sub>ANT</sub> = 50 Ω
RX terminating impedance:	Z <sub>RX</sub> = 100 Ω (balanced)
TX terminating impedance:	Z <sub>TX</sub> = 50 Ω

<b>Characterisitcs TX - ANT</b>	<b>min.</b>	<b>typ. @ 25 °C</b>	<b>max.</b>	
<b>Attenuation</b>				$\alpha$
0.3 ... 779.0 MHz	30	40		
779.0 ... 804.0 MHz	30	41		
@f <sub>Carrier</sub> 871.4 ... 891.6 MHz	45	54		$\alpha_{WCDMA}^{1)}$
1574.0 ... 1577.0 MHz	43	54		
1648.0 ... 1698.0 MHz	30	48		
2400.0 ... 2500.0 MHz	30	35		
2500.0 ... 2547.0 MHz	29	34		
2547.0 ... 4120.0 MHz	10	16		
4120.0 ... 4245.0 MHz	15	24		
4245.0 ... 5150.0 MHz	10	13		
5150.0 ... 5825.0 MHz	8	11		

1) Attenuation of W-CDMA signal (power transfer function). Please refer to annotation on page (11).



<b>SAW Components</b>	<b>B7690</b>
<b>SAW Duplexer</b>	<b>836.5 / 881.5 MHz</b>

Data Sheet



**Characteristics for W-CDMA Band 5**

Temperature range for specification: T = -15 °C to +80 °C  
 Antenna terminating impedance: Z<sub>ANT</sub> = 50 Ω  
 RX terminating impedance: Z<sub>RX</sub> = 100 Ω (balanced)  
 TX terminating impedance: Z<sub>TX</sub> = 50 Ω

Characteristics ANT - RX	min.	typ. @ 25 °C	max.	
<b>Center frequency</b> f <sub>c</sub>		881.5		MHz
<b>Maximum insertion attenuation</b> @f <sub>Carrier</sub> 871.4 ... 891.6 MHz α <sub>WCDMA</sub> <sup>1)</sup>		1.8	2.5	dB
<b>Amplitude ripple (p-p)</b> @f <sub>Carrier</sub> 871.4 ... 891.6 MHz Δα <sub>WCDMA</sub>		0.6	1.1	dB
<b>Error Vector Magnitude</b> @f <sub>Carrier</sub> 871.4 ... 891.6 MHz EVM <sup>2)</sup>		1.8	3.0	%
<b>Input VSWR (ANT port)</b> 869.0 ... 894.0 MHz		1.6	1.8	
<b>Output VSWR (RX port)</b> 869.0 ... 894.0 MHz		1.9	2.2	
<b>CMRR ( S<sub>32</sub>-S<sub>42</sub> / S<sub>32</sub>+S<sub>42</sub> )</b> 869.0 ... 894.0 MHz	20 <sup>3)</sup>	30		dB

<sup>1)</sup> Attenuation of W-CDMA signal (power transfer function). Please refer to annotation on page (11).

<sup>2)</sup> Error Vector Magnitude (EVM) based on definition given in 3GPP TS 25.141.

<sup>3)</sup> A combination of 10 ° phase balance and 1 dB amplitude balance corresponds to 19.6 dB CMRR



**SAW Components**

**B7690**

**SAW Duplexer**

**836.5 / 881.5 MHz**

**Data Sheet**



**Characteristics for W-CDMA Band 5**

Temperature range for specification: T = -15 °C to +80 °C  
 Antenna terminating impedance: Z<sub>ANT</sub> = 50 Ω  
 RX terminating impedance: Z<sub>RX</sub> = 100 Ω (balanced)  
 TX terminating impedance: Z<sub>TX</sub> = 50 Ω

<b>Characterisitcs ANT - RX</b>					<b>min.</b>	<b>typ. @ 25 °C</b>	<b>max.</b>		
<b>IMD product level limits<sup>1)</sup></b>									
<b>at f<sub>TX</sub> = 836.5 MHz f<sub>RX</sub> = 881.5 MHz</b>									
Blocker 1		45.0	MHz			-108	-105	dBm	
Blocker 2		791.5	MHz			-128	-110	dBm	
Blocker 3		1718.0	MHz			-121	-110	dBm	
<b>Attenuation</b>									
				α					
	0.3	...	779.0	MHz	40	57		dB	
			779.0	...	824.0	MHz	40	57	dB
@f <sub>Carrier</sub>	826.4	...	846.6	MHz	α <sub>WCDMA</sub> <sup>2)</sup>	47	55	dB	
	849.0	...	854.0	MHz		23	45	dB	
	914.0	...	1693.0	MHz		23	37	dB	
	1693.0	...	1788.0	MHz		45	63	dB	
	1788.0	...	2400.0	MHz		40	57	dB	
	2400.0	...	2500.0	MHz		40	50	dB	
	2500.0	...	2682.0	MHz		40	47	dB	
	2682.0	...	4480.0	MHz		40	44	dB	

1) Power levels: 21dBm Tx signal, -15dBm blocker at antenna port.

2) Attenuation of WCDMA signal ("Powertransferfunction"). Please refer to annotation on page (11).

<b>Characterisitcs TX - RX</b>					<b>min.</b>	<b>typ. @ 25 °C</b>	<b>max.</b>	
<b>Isolation</b>								
				α				
@f <sub>Carrier</sub>	826.4	...	846.6	MHz	α <sub>WCDMA</sub> <sup>1)</sup>	54	58	dB
@f <sub>Carrier</sub>	871.4	...	891.6	MHz	α <sub>WCDMA</sub>	50	55	dB
<b>Common Mode Isolation</b>								
				α				
@f <sub>Carrier</sub>	826.4	...	846.6	MHz	α <sub>WCDMA</sub>	42	48	dB

1) Attenuation of W-CDMA signal (power transfer function). Please refer to annotation on page (11).



<b>SAW Components</b>	<b>B7690</b>
<b>SAW Duplexer</b>	<b>836.5 / 881.5 MHz</b>

Data Sheet

**SMD**

**Characteristics for CDMA 800**

Temperature range for specification: T = -30 °C to +85 °C  
 Antenna terminating impedance: Z<sub>ANT</sub> = 50 Ω  
 RX terminating impedance: Z<sub>RX</sub> = 100 Ω (balanced)  
 TX terminating impedance: Z<sub>TX</sub> = 50 Ω

<b>Characterisitcs TX - ANT</b>	<b>min.</b>	<b>typ. @ 25 °C</b>	<b>max.</b>	
<b>Center frequency</b> f <sub>c</sub>		836.5		MHz
<b>Maximum insertion attenuation</b> 824.0 ... 849.0 MHz α		1.5	2.5	dB
<b>Input VSWR (TX port)</b> 824.0 ... 849.0 MHz		1.7	2.0	
<b>Output VSWR (ANT port)</b> 824.0 ... 849.0 MHz		1.6	2.0	



SAW Components

B7690

SAW Duplexer

836.5 / 881.5 MHz

Data Sheet

**SMD**

**Characteristics for CDMA 800**

Temperature range for specification: T = -30 °C to +85 °C  
 Antenna terminating impedance: Z<sub>ANT</sub> = 50 Ω  
 RX terminating impedance: Z<sub>RX</sub> = 100 Ω (balanced)  
 TX terminating impedance: Z<sub>TX</sub> = 50 Ω

Characterisitcs TX - ANT				min.	typ. @ 25 °C	max.	
<b>Attenuation</b>			α				
	10.0	...	804.0 MHz	30	40		dB
	869.0	...	894.0 MHz	44	53		dB
	1574.0	...	1577.0 MHz	45	54		dB
	1648.0	...	1698.0 MHz	30	47		dB
	1884.0	...	1919.0 MHz	20	42		dB
	1930.0	...	1990.0 MHz	27	41		dB
	2110.0	...	2170.0 MHz	27	39		dB
	2400.0	...	2500.0 MHz	30	35		dB
	2500.0	...	2547.0 MHz	29	34		dB
	3286.0	...	3406.0 MHz	15	22		dB



<b>SAW Components</b>	<b>B7690</b>
<b>SAW Duplexer</b>	<b>836.5 / 881.5 MHz</b>

Data Sheet

**SMD**

**Characteristics for CDMA 800**

Temperature range for specification: T = -30 °C to +85 °C  
 Antenna terminating impedance: Z<sub>ANT</sub> = 50 Ω  
 RX terminating impedance: Z<sub>RX</sub> = 100 Ω (balanced)  
 TX terminating impedance: Z<sub>TX</sub> = 50 Ω

Characteristics ANT - RX	min.	typ. @ 25 °C	max.	
<b>Center frequency</b> f <sub>c</sub>		881.5		MHz
<b>Maximum insertion attenuation</b> 869.0 ... 894.0 MHz α <sub>max</sub>		2.0	3.0	dB
<b>Input VSWR (ANT port)</b> 869.0 ... 894.0 MHz		1.6	2.0	
<b>Output VSWR (RX port)</b> 869.0 ... 894.0 MHz		1.9	2.2	
<b>CMRR</b> ( S <sub>32</sub> -S <sub>42</sub>  / S <sub>32</sub> +S <sub>42</sub>  ) 869.0 ... 894.0 MHz	20 <sup>1)</sup>	30		dB

<sup>1)</sup> A combination of 10 ° phase balance and 1 dB amplitude balance corresponds to 19.6 dB CMRR



**SAW Components** **B7690**

**SAW Duplexer** **836.5 / 881.5 MHz**

Data Sheet



**Characteristics for CDMA 800**

Temperature range for specification:  $T = -30\text{ °C to }+85\text{ °C}$   
 Antenna terminating impedance:  $Z_{ANT} = 50\ \Omega$   
 RX terminating impedance:  $Z_{RX} = 100\ \Omega$  (balanced)  
 TX terminating impedance:  $Z_{TX} = 50\ \Omega$

<b>Characterisitcs ANT - RX</b>				<b>min.</b>	<b>typ. @ 25 °C</b>	<b>max.</b>	
<b>Attenuation</b>			$\alpha$				
	10.0	...	824.0 MHz	40	57		dB
	824.0	...	849.0 MHz	45	54		dB
	970.0	...	4800.0 MHz	40	44		dB
	4800.0	...	6000.0 MHz	30	43		dB
	1750.0	...	1780.0 MHz	45	63		dB
	1850.0	...	1910.0 MHz	45	61		dB
	1920.0	...	1980.0 MHz	45	61		dB

<b>Characterisitcs TX - RX</b>				<b>min.</b>	<b>typ. @ 25 °C</b>	<b>max.</b>	
<b>Isolation</b>			$\alpha$				
	824.0	...	849.0 MHz	50	56		dB
	869.0	...	894.0 MHz	48	54		dB



**SAW Components** **B7690**

**SAW Duplexer** **836.5 / 881.5 MHz**

**Data Sheet** **SMD**

**Maximum Ratings**

Temperature range for specification <sup>1)</sup>	T	-30/+85	°C	
Storage temperature range	T <sub>stg</sub>	-40/+85	°C	
DC voltage	V <sub>DC</sub>	5	V	
ESD voltage	V <sub>ESD</sub>	100 <sup>2)</sup>	V	machine model, 10 pulses
Input power at	P <sub>IN</sub>			source and load impedance 50 Ω
824.0 ... 849.0 MHz		30	dBm	} continuous wave T = 55°C, 50.000 h
elsewhere		10	dBm	

1) Defines the temperature range for specification values.

2) acc. to JESD22-A115A (machine model), 10 negative & 10 positive pulses.

**Annotation for characteristics section**

Attenuation of WCDMA signal ("Powertransferfunction",  $\alpha_{WCDMA}$ ) is determined by

$$\int_{-\infty}^{\infty} |S_{ds21}(f)H_{RRC}(f - f_{Carrier})|^2 df$$

$f_{Carrier}$  according to 3GPP TS 25.101 (e.g. for WCDMA Band 5-Passband,  $f_{Carrier}$  ranges from 826.4 MHz (lowest Tx channel) to 846.6 MHz (highest Tx channel)).  $H_{RRC}(f)$  is the transfer function of the root-raised cosine transmit pulse shaping filter according to 3GPP TS 25.101 with the following normalization:

$$\int_{-\infty}^{\infty} |H_{RRC}(f)|^2 df = 1$$



SAW Components

B7690

SAW Duplexer

836.5 / 881.5 MHz

Data Sheet



Frequency Response TX-ANT for W-CDMA Band 5

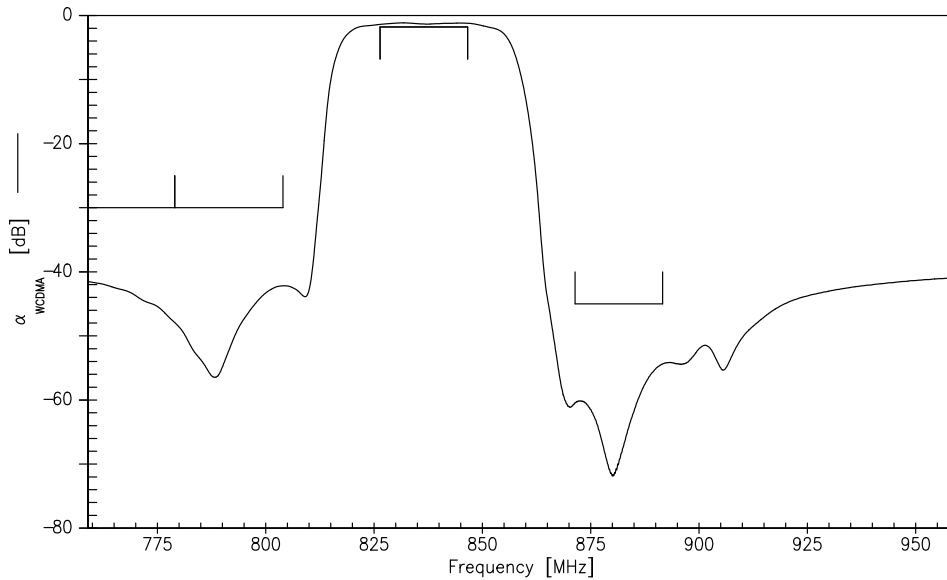

Frequency Response TX-ANT (wideband) for W-CDMA Band 5

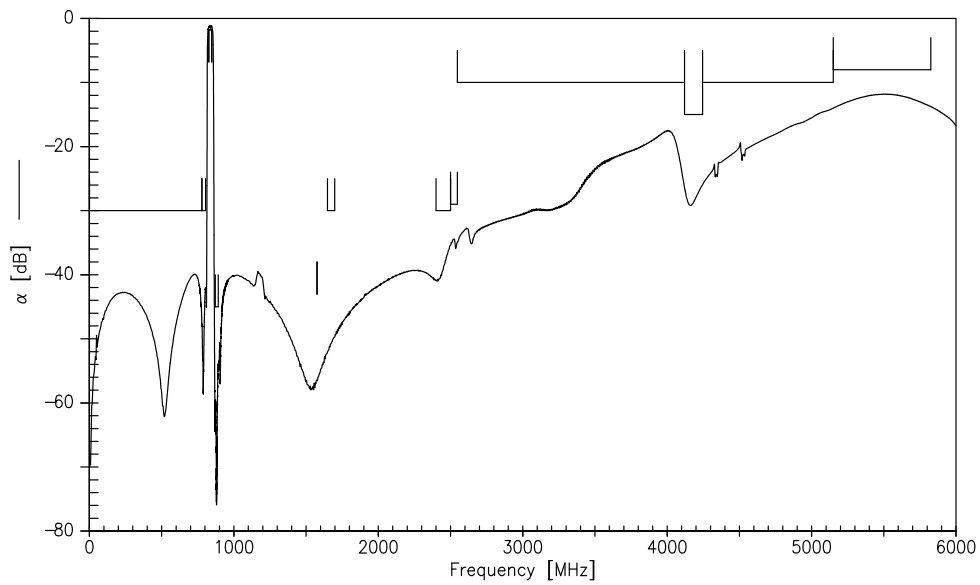

Please read *cautions and warnings* and *important notes* at the end of this document.



SAW Components

B7690

SAW Duplexer

836.5 / 881.5 MHz

Data Sheet



Frequency Response ANT-RX for W-CDMA Band 5

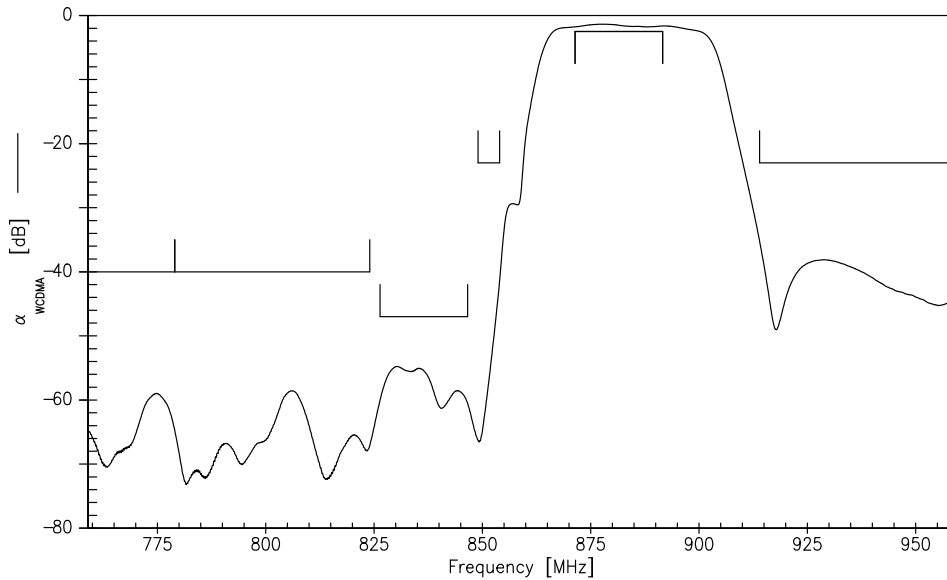

Frequency Response ANT-RX (wideband) for W-CDMA Band 5

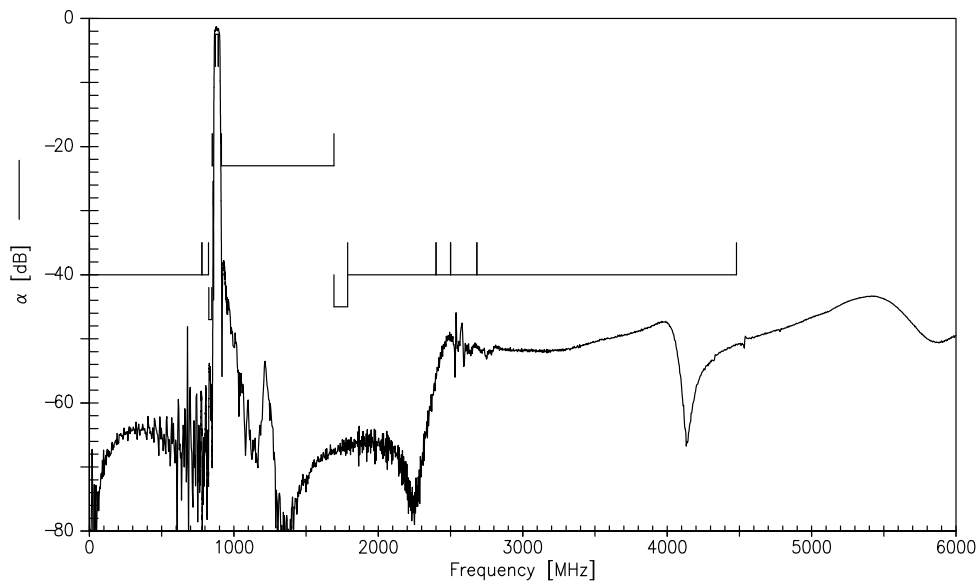

Please read *cautions and warnings* and *important notes* at the end of this document.



SAW Components

B7690

SAW Duplexer

836.5 / 881.5 MHz

Data Sheet



Frequency Response TX-RX for W-CDMA Band 5

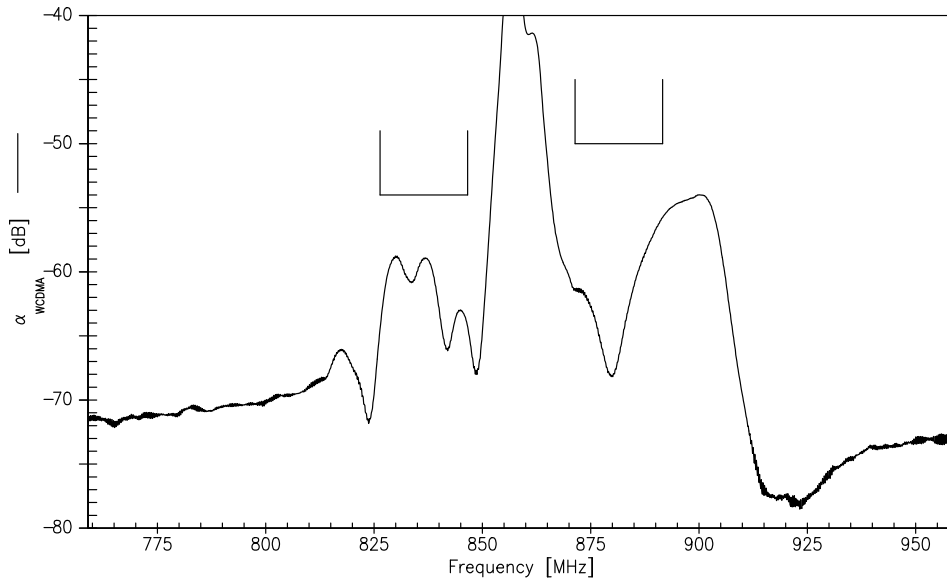

Frequency Response TX-RX (wideband) for WCDMA Band 5

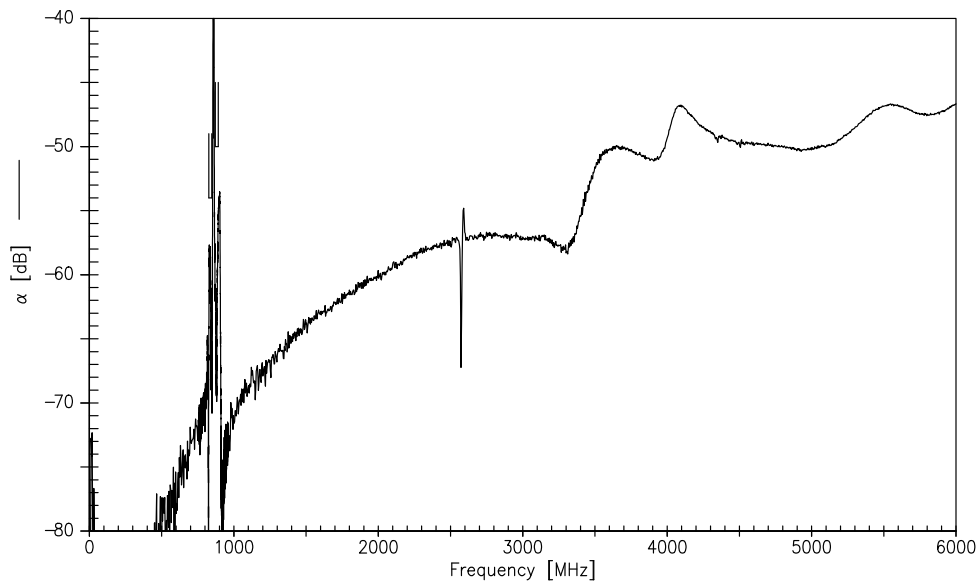

Please read *cautions and warnings* and *important notes* at the end of this document.

Matching

**S<sub>11</sub> (TX) VSWR**

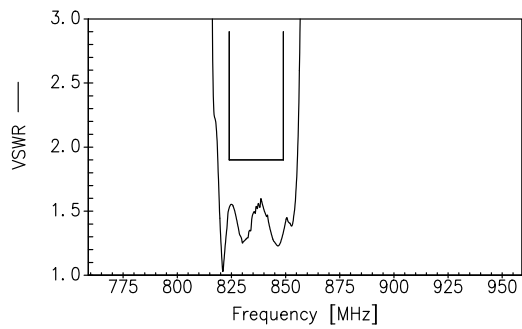

**S<sub>11</sub> (TX)**

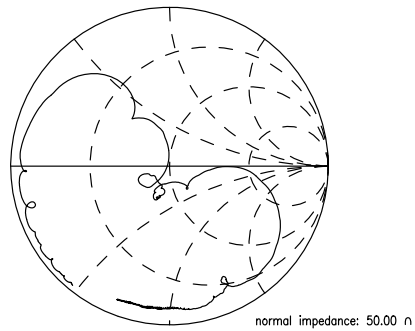

**S<sub>22</sub> (ANT) VSWR**

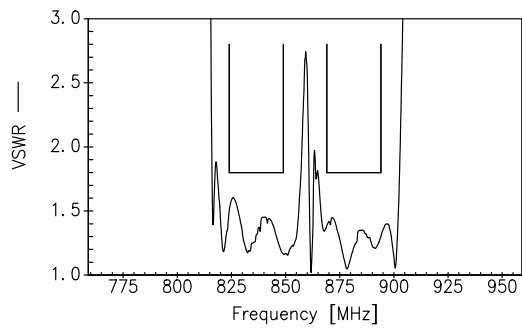

**S<sub>22</sub> (ANT)**

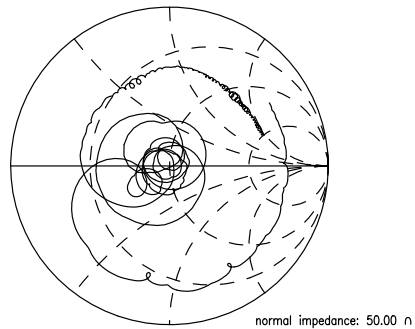

**S<sub>33</sub> (RX) VSWR**

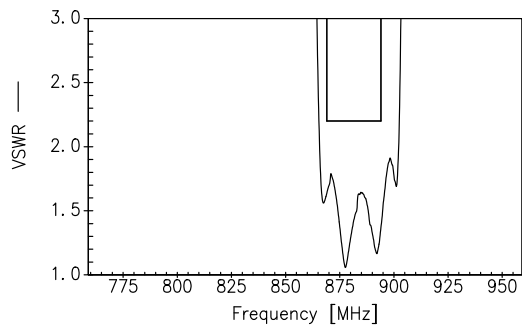

**S<sub>33</sub> (RX)**

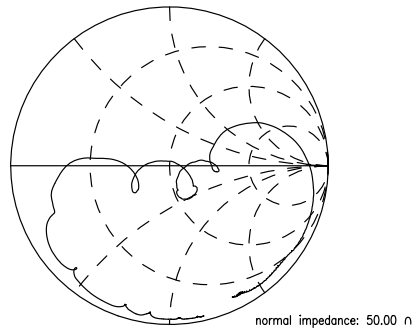



SAW Components

B7690

SAW Duplexer

836.5 / 881.5 MHz

Data Sheet



Frequency Response TX-ANT for CDMA 800

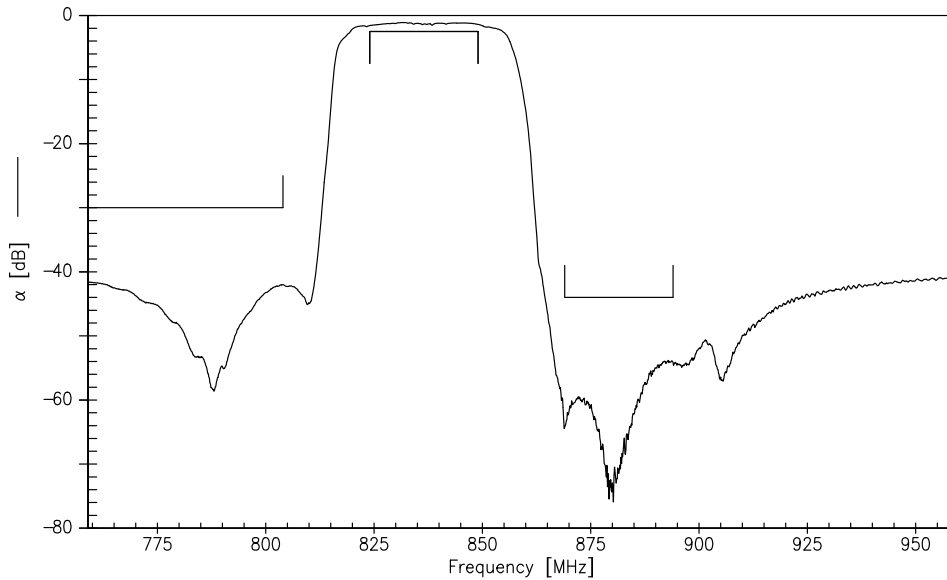

Frequency Response TX-ANT (wideband) for CDMA 800

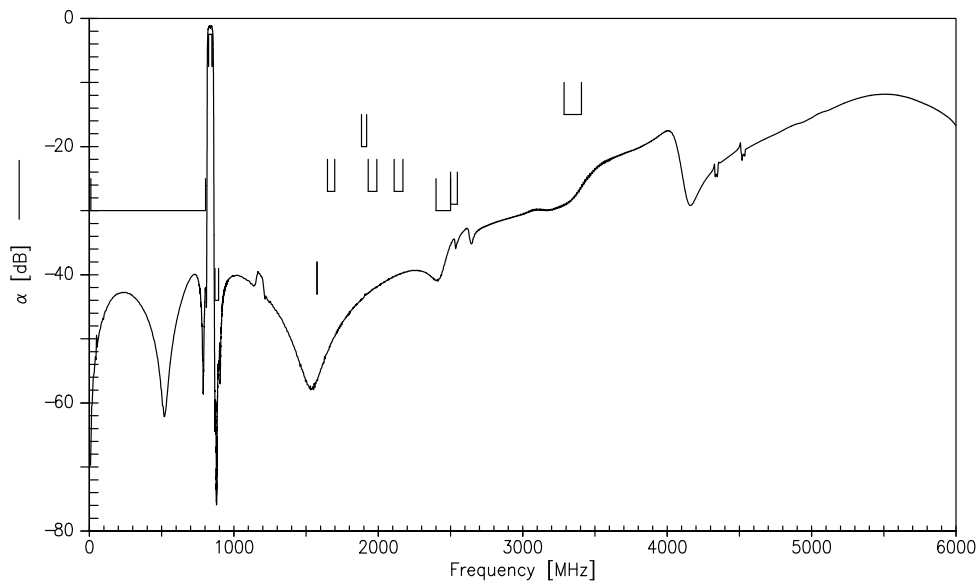

Please read *cautions and warnings* and *important notes* at the end of this document.



Frequency Response ANT-RX for CDMA 800

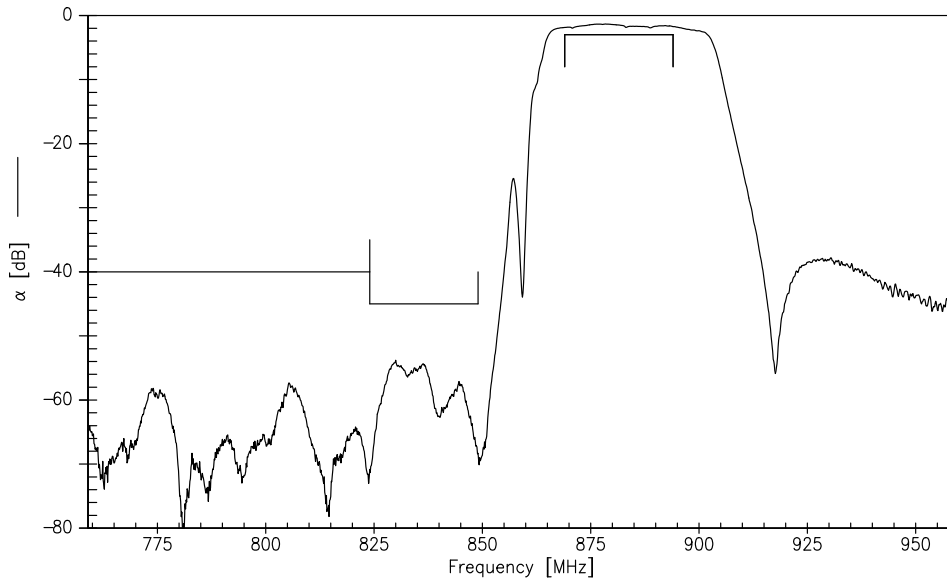

Frequency Response ANT-RX (wideband) for CDMA 800

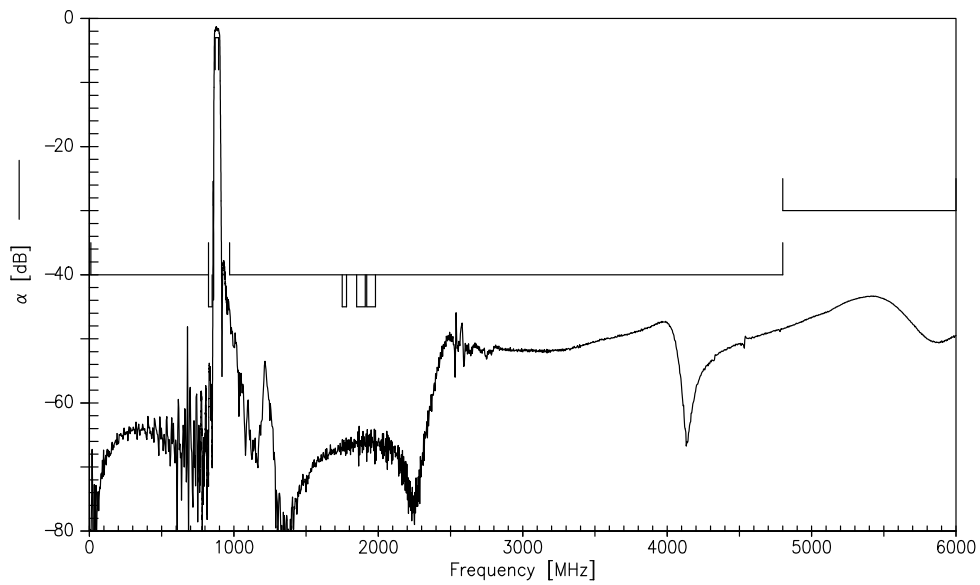



SAW Components

B7690

SAW Duplexer

836.5 / 881.5 MHz

Data Sheet



### Frequency Response TX-RX for CDMA 800

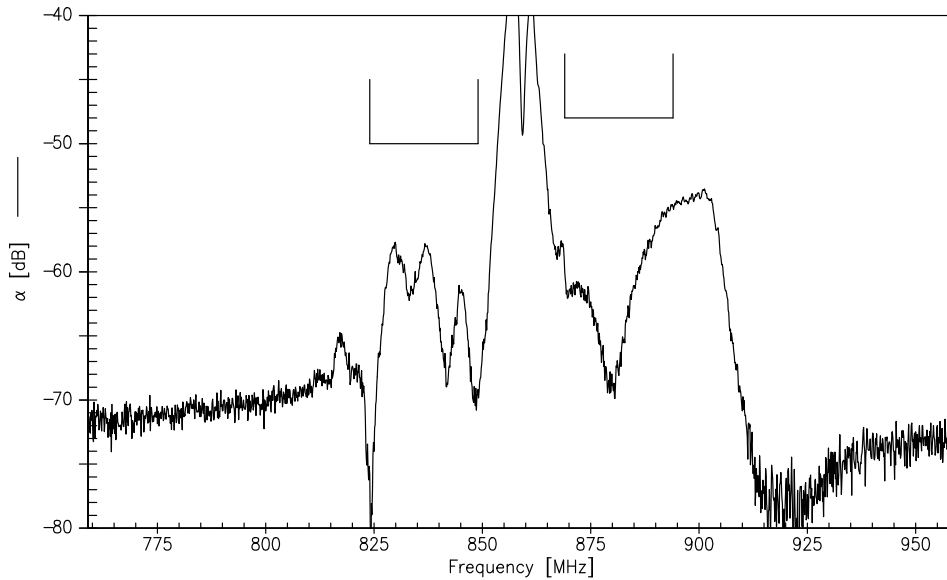

### Frequency Response TX-RX (wideband) for CDMA 800

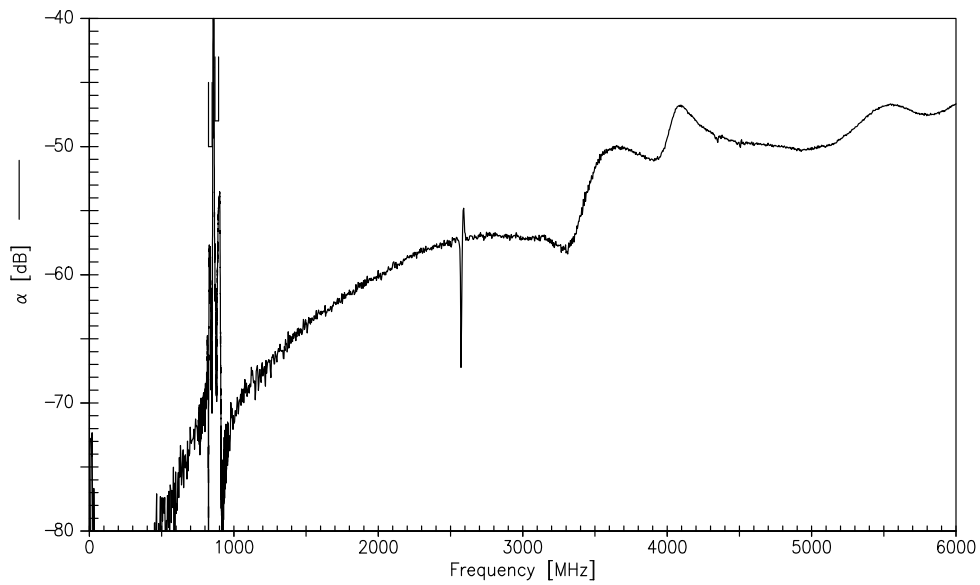

Please read *cautions and warnings* and *important notes* at the end of this document.



<b>SAW Components</b>	<b>B7690</b>
<b>SAW Duplexer</b>	<b>836.5 / 881.5 MHz</b>

Data Sheet



References

<b>Type</b>	B7690
<b>Ordering code</b>	B39881B7690A710
<b>Marking and package</b>	C61157-A3-A49
<b>Packaging</b>	F61074-V8211-Z000
<b>Date codes</b>	L_1126
<b>S-parameters</b>	B7690_NB.s4p B7690_WB.s4p See file header for pin/port assignment.
<b>Soldering profile</b>	S_6001
<b>RoHS compatible</b>	defined as compatible with the following documents: "DIRECTIVE 2002/95/EC OF THE EUROPEAN PARLIAMENT AND OF THE COUNCIL of 27 January 2003 on the restriction of the use of certain hazardous substances in electrical and electronic equipment. 2005/618/EC from April 18th, 2005, amending Directive 2002/95/EC of the European Parliament and of the Council for the purposes of establishing the maximum concentration values for certain hazardous substances in electrical and electronic equipment."

For further information please contact your local EPCOS sales office or visit our webpage at [www.epcos.com](http://www.epcos.com).

Published by EPCOS AG  
Surface Acoustic Wave Components Division  
P.O. Box 80 17 09, 81617 Munich, GERMANY

© EPCOS AG 2008. This brochure replaces the previous edition.

For questions on technology, prices and delivery please contact the Sales Offices of EPCOS AG or the international Representatives.

Due to technical requirements components may contain dangerous substances. For information on the type in question please also contact one of our Sales Offices.

Please read *cautions and warnings and important notes* at the end of this document.



The following applies to all products named in this publication:

1. Some parts of this publication contain **statements about the suitability of our products for certain areas of application**. These statements are based on our knowledge of typical requirements that are often placed on our products in the areas of application concerned. We nevertheless expressly point out **that such statements cannot be regarded as binding statements about the suitability of our products for a particular customer application**. As a rule, EPCOS is either unfamiliar with individual customer applications or less familiar with them than the customers themselves. For these reasons, it is always ultimately incumbent on the customer to check and decide whether an EPCOS product with the properties described in the product specification is suitable for use in a particular customer application.
2. We also point out that **in individual cases, a malfunction of electronic components or failure before the end of their usual service life cannot be completely ruled out in the current state of the art, even if they are operated as specified**. In customer applications requiring a very high level of operational safety and especially in customer applications in which the malfunction or failure of an electronic component could endanger human life or health (e.g. in accident prevention or life-saving systems), it must therefore be ensured by means of suitable design of the customer application or other action taken by the customer (e.g. installation of protective circuitry or redundancy) that no injury or damage is sustained by third parties in the event of malfunction or failure of an electronic component.
3. **The warnings, cautions and product-specific notes must be observed.**
4. In order to satisfy certain technical requirements, **some of the products described in this publication may contain substances subject to restrictions in certain jurisdictions (e.g. because they are classed as hazardous)**. Useful information on this will be found in our Material Data Sheets on the Internet ([www.epcos.com/material](http://www.epcos.com/material)). Should you have any more detailed questions, please contact our sales offices.
5. We constantly strive to improve our products. Consequently, **the products described in this publication may change from time to time**. The same is true of the corresponding product specifications. Please check therefore to what extent product descriptions and specifications contained in this publication are still applicable before or when you place an order. We also **reserve the right to discontinue production and delivery of products**. Consequently, we cannot guarantee that all products named in this publication will always be available. The aforementioned does not apply in the case of individual agreements deviating from the foregoing for customer-specific products.
6. Unless otherwise agreed in individual contracts, **all orders are subject to the current version of the "General Terms of Delivery for Products and Services in the Electrical Industry" published by the German Electrical and Electronics Industry Association (ZVEI)**.
7. The trade names EPCOS, BAOKE, Alu-X, CeraDiode, CSSP, CTVS, DSSP, MiniBlue, MKK, MLSC, MotorCap, PCC, PhaseCap, PhaseMod, SIFERRIT, SIFI, SIKOREL, SilverCap, SIM-DAD, SIMID, SineFormer, SIOV, SIP5D, SIP5K, ThermoFuse, WindCap are **trademarks registered or pending** in Europe and in other countries. Further information will be found on the Internet at [www.epcos.com/trademarks](http://www.epcos.com/trademarks).