



RJ45 Jacks with integrated magnetics

10/100 Base-T, single port, tab down

Series/Type: B78477P1***A*14

Date: February 2010

Applications

- Local Area Networks using Ethernet protocol
- Hubs, switches, routers
- ADSL modems
- Industrial automation equipment using Ethernet protocol for communication

Features

- Fully compliant with IEEE 802.3, IEEE 802.3af (B78477P1001A314)
- With EMI fingers for shielding
- High electrical performance and EMI suppression
- Optimized for all major transceiver ICs
- Industry standard footprint
- RoHS-compatible

Construction

- Housing: Thermoplastic, UL 94 V-0
- Shield: Ni plated on copper alloy
- Contact: Phosphor bronze, 1.27 μm (50 $\mu\text{''}$) Ni underplating, 0.4 μm (15 $\mu\text{''}$) selective gold plating
- Connector dimensions comply with TIA-968 (FCC 68.5) dimension requirements

Marking

- EPCOS, middle block of ordering code, date code

Delivery mode and packing unit

- Blister trays in carton box
- Packing unit: 512 pcs. per carton box (8 trays), B78477P1001A314: 640 pcs.

Overview and ordering codes

Operating temperature range	LED (left - right)	Ordering code
0 °C ... +70 °C	Green - yellow	B78477P1004A314
	Green - yellow	B78477P1005A314
	Yellow - green	B78477P1006A114
	Yellow - green	B78477P1007A114
	–	B78477P1003A014
–40 °C ... +85 °C	Green - yellow	B78477P1001A314
	–	B78477P1002A014

Mechanical characteristics

Insertion force	20 N max.
Retention force	75 N min.
Durability	750 mating cycles min.

LED specification

LED colour	Wave length	Forward voltage	
		Max.	Typical
Green	565 nm	2.6 V	2.2 V
Yellow	585 nm	2.6 V	2.1 V

Characteristics

B78477P1001A314

(electrical specifications at 25 °C)

Turns ratio (primary : secondary)	1.414 : 1 ±3%	
Inductance L	350 µH min.	100 kHz, 100 mV, 8 mA DC bias
Voltage test V_{test} (primary : secondary) (primary : shield)	1500 V_{RMS} 1500 V_{RMS}	0.5 mA, 50 Hz, 1 min ¹⁾ 0.5 mA, 50 Hz, 1 min ¹⁾
DCR (1/2 winding)	0.6 Ω max.	
DCR Balance	±0.065 Ω max.	center tap symmetry
Insertion loss	-1.2 dB max.	0.1 MHz
Return loss	-16 dB min. -10+20log(f/60) dB min. -10 dB min.	0.1 MHz ... 30 MHz 30 MHz ... 60 MHz 60 MHz ... 80 MHz
Crosstalk	-50 dB min. -50+17log(f/10) dB min.	1 MHz 10 MHz ... 100 MHz
Common-mode rejection	-50 dB typ. -15+17log(f/200) dB typ.	2 MHz 30 MHz ... 200 MHz
Weight	Approx. 5.7 g	

 1) On mass manufacture will be 2 s to HV_{test}

Characteristics

B78477P1002A014, B78477P1003A014,
 B78477P1004A314, B78477P1006A114,
 B78477P1007A114

(electrical specifications at 25 °C)

Turns ratio (primary : secondary)	1CT : 1CT ±3%	
Inductance L	350 µH min.	100 kHz, 100 mV, 8 mA DC bias
Voltage test V_{test} (primary : secondary)	1500 V AC	50 Hz, 1 min
Insertion loss	-1.0 dB max.	1 MHz ... 100 MHz
Return loss	-18 dB min. -14 dB min. -12 dB min. -10 dB min.	1 MHz ... 40 MHz 60 MHz 80 MHz 100 MHz
Crosstalk	-33 dB min.	1 MHz ... 100 MHz
Common-mode rejection	-30 dB typ.	1 MHz ... 100 MHz
Weight	Approx. 5.7 g	

Characteristics

B78477P1005A314

(electrical specifications at 25 °C)

Turns ratio (primary : secondary)	1CT : 1 ±3%	
Inductance L	350 µH min.	100 kHz, 100 mV, 8 mA DC bias
Voltage test V_{test} (primary : secondary)	1500 V AC	50 Hz, 1 min
Insertion loss	-1.0 dB max.	1 MHz ... 100 MHz
Return loss	-18 dB min. -14 dB min. -12 dB min. -10 dB min.	1 MHz ... 40 MHz 60 MHz 80 MHz 100 MHz
Crosstalk	-33 dB min.	1 MHz ... 100 MHz
Common-mode rejection	-30 dB typ.	1 MHz ... 100 MHz
Weight	Approx. 5.7 g	

Dimensional drawing for B78477P1001A314

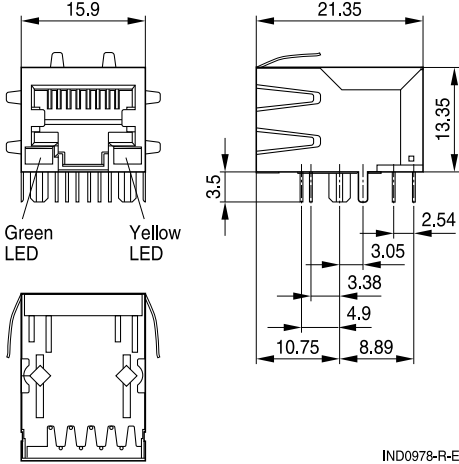

Layout recommendation (top view)

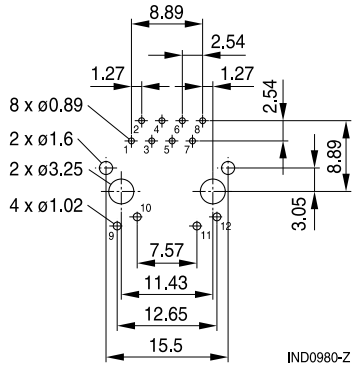

Dimensions in mm

Values without tolerances are nominal values for reference.

Pinning

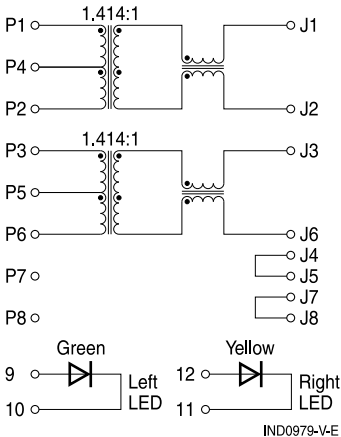

Dimensional drawing for B78477P1002A014 and B78477P1003A014

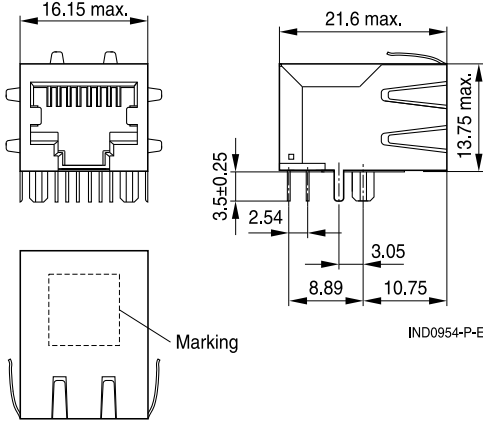

Layout recommendation (top view)

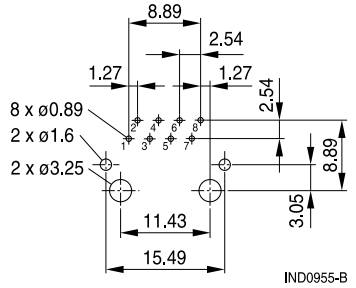

Dimensions in mm

Values without tolerances are nominal values for reference.

Pinnings

B78477P1002A014

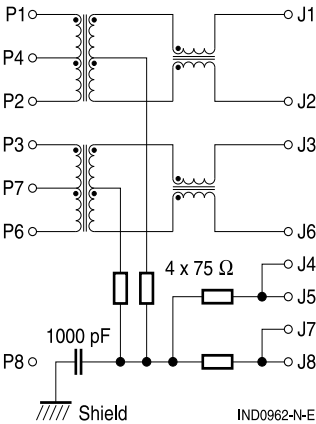

B78477P1003A014

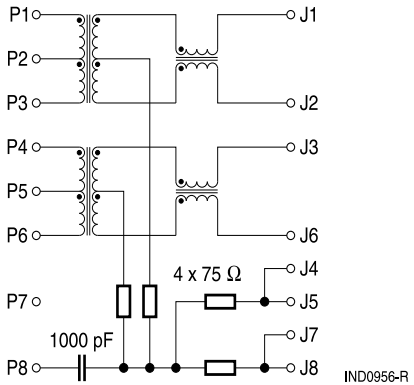

Dimensional drawing for B78477P1004A314 and B78477P1005A314

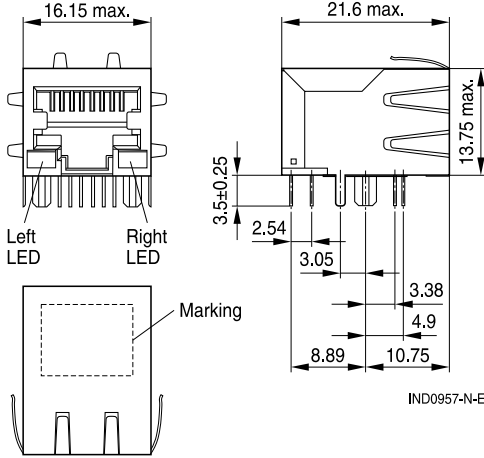

Layout recommendation (top view)

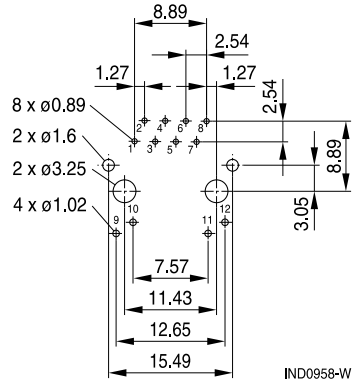

Dimensions in mm

Values without tolerances are nominal values for reference.

Pinnings

B78477P1004A314

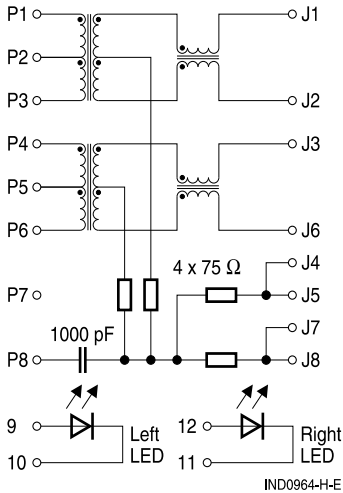

B78477P1005A314

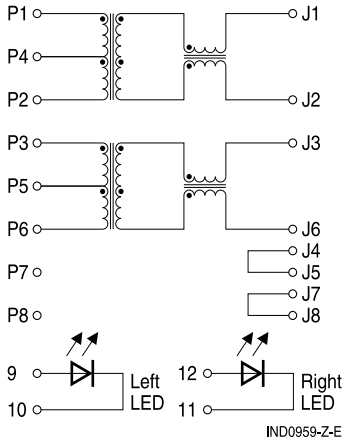

Dimensional drawing for B78477P1006A114 and B78477P1007A114

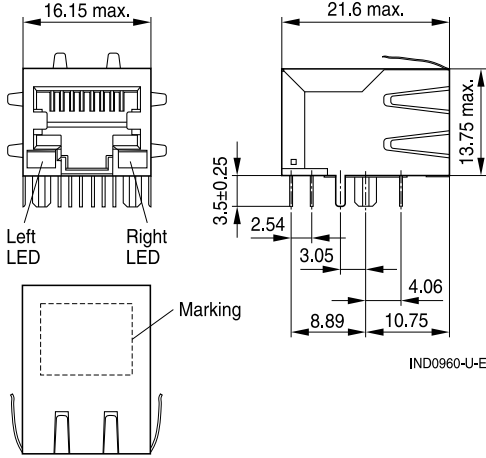

IND0960-U-E

Layout recommendation (top view)

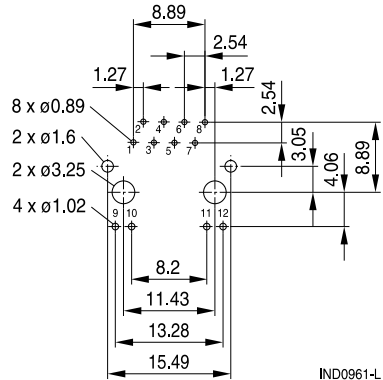

IND0961-L

Dimensions in mm

Values without tolerances are nominal values for reference.

Pinnings

B78477P1006A114

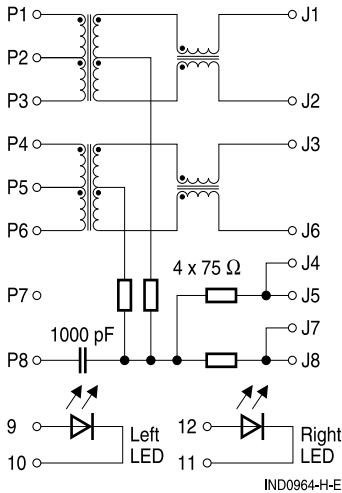

IND0964-H-E

B78477P1007A114

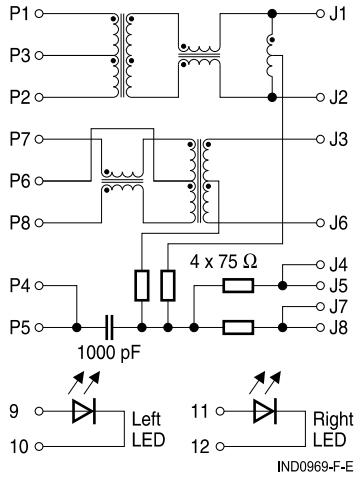

IND0969-F-E

Cautions and warnings

- If the components are to be washed varnished it is necessary to check whether the washing varnish agent that is used has a negative effect on the wire insulation, any plastics that are used, or on glued joints. In particular, it is possible for washing varnish agent residues to have a negative effect in the long-term on wire insulation.
- The following points must be observed if the components are potted in customer applications:
 - Many potting materials shrink as they harden. They therefore exert a pressure on the plastic housing or core. This pressure can have a deleterious effect on electrical properties, and in extreme cases can damage the core or plastic housing mechanically.
 - It is necessary to check whether the potting material used attacks or destroys the wire insulation, plastics or glue.
 - The effect of the potting material can change the high-frequency behaviour of the components.
- Ferrites are sensitive to direct impact. This can cause the core material to flake, or lead to breakage of the core.
- Even for customer-specific products, conclusive validation of the component in the circuit can only be carried out by the customer.

Important notes

The following applies to all products named in this publication:

1. Some parts of this publication contain **statements about the suitability of our products for certain areas of application**. These statements are based on our knowledge of typical requirements that are often placed on our products in the areas of application concerned. We nevertheless expressly point out **that such statements cannot be regarded as binding statements about the suitability of our products for a particular customer application**. As a rule, EPCOS is either unfamiliar with individual customer applications or less familiar with them than the customers themselves. For these reasons, it is always ultimately incumbent on the customer to check and decide whether an EPCOS product with the properties described in the product specification is suitable for use in a particular customer application.
2. We also point out that **in individual cases, a malfunction of electronic components or failure before the end of their usual service life cannot be completely ruled out in the current state of the art, even if they are operated as specified**. In customer applications requiring a very high level of operational safety and especially in customer applications in which the malfunction or failure of an electronic component could endanger human life or health (e.g. in accident prevention or lifesaving systems), it must therefore be ensured by means of suitable design of the customer application or other action taken by the customer (e.g. installation of protective circuitry or redundancy) that no injury or damage is sustained by third parties in the event of malfunction or failure of an electronic component.
3. **The warnings, cautions and product-specific notes must be observed.**
4. In order to satisfy certain technical requirements, **some of the products described in this publication may contain substances subject to restrictions in certain jurisdictions (e.g. because they are classed as hazardous)**. Useful information on this will be found in our Material Data Sheets on the Internet (www.epcos.com/material). Should you have any more detailed questions, please contact our sales offices.
5. We constantly strive to improve our products. Consequently, **the products described in this publication may change from time to time**. The same is true of the corresponding product specifications. Please check therefore to what extent product descriptions and specifications contained in this publication are still applicable before or when you place an order. We also **reserve the right to discontinue production and delivery of products**. Consequently, we cannot guarantee that all products named in this publication will always be available. The aforementioned does not apply in the case of individual agreements deviating from the foregoing for customer-specific products.
6. Unless otherwise agreed in individual contracts, **all orders are subject to the current version of the "General Terms of Delivery for Products and Services in the Electrical Industry" published by the German Electrical and Electronics Industry Association (ZVEI)**.
7. The trade names EPCOS, BAOKE, Alu-X, CeraDiode, CSMP, CSSP, CTVS, DeltaCap, DigiSiMic, DSSP, MiniBlue, MiniCell, MKK, MLSC, MotorCap, PCC, PhaseCap, PhaseCube, PhaseMod, PhiCap, SIFERRIT, SIFI, SIKOREL, SilverCap, SIMDAD, SiMic, SIMID, SineFormer, SIOV, SIP5D, SIP5K, ThermoFuse, WindCap are **trademarks registered or pending** in Europe and in other countries. Further information will be found on the Internet at www.epcos.com/trademarks.