



Data and signal line chokes

SIMDAD 1210, common-mode chokes
42 V AC/80 V DC, 11 ... 100 μ H, 150 ... 300 mA

Series/Type: B82788C0/S0

Date: October 2008, March 2009

SIMDAD 1210, common-mode chokes

Preliminary data

SMD

Rated voltage 42 V AC/80 V DC
Rated inductance 11 μ H to 100 μ H
Rated current 150 mA to 300 mA



Construction

- Current-compensated double choke
- Ferrite I core
- Winding: Enamel copper wire
- Winding welded to terminals
- Bifilar winding (B82788C0...)
- Sector winding (B82788S0...)

Features

- Temperature range up to 150 °C
- Suitable for lead-free reflow soldering as referenced in JEDEC J-STD 020C
- RoHS-compatible

Function

- B82788C0:
Suppression of asymmetrical interference coupled in on lines, whereas data signals up to some MHz can pass unaffectedly.
- B82788S0:
Suppression of asymmetrical (by L_R) and symmetrical interference (by L_{stray}) coupled in on lines. The high-frequency portions of the symmetrical data signal are decreased so far that EMC problems can be significantly reduced.

Applications

- Automotive applications (CAN and FlexRay bus)
- Industrial field bus systems
- Line cards for telecommunications

Terminals

Tinned terminals (B82788*H052):

- Base material CuSn6
- Layer composition Ni, Sn
- Lead-free tinned

SIMDAD 1210, common-mode chokes

Preliminary data

SMD

Marking

- Marking on component:
Manufacturer, bifilar or sector winding (coded),
L value (in nH),
date of manufacture (YWWD), two last digits of production order
- Minimum data on reel:
Manufacturer, ordering code,
L value (in nH), quantity, date of packing

Delivery mode and packing unit

- 12-mm blister tape, wound on 330-mm Ø reel
- Packing unit: 5000 pcs./reel

SIMDAD 1210, common-mode chokes

Preliminary data

SMD

Dimensional drawing and layout recommendation

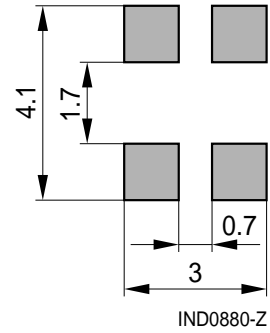
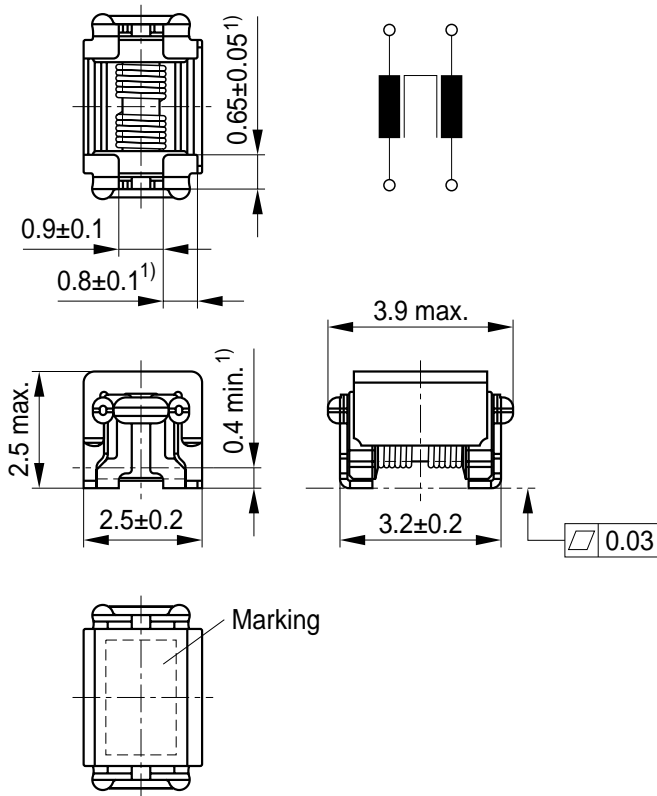

¹⁾ Soldering area

IND0758-W-E

Dimensions in mm

Taping and packing

Blister tape

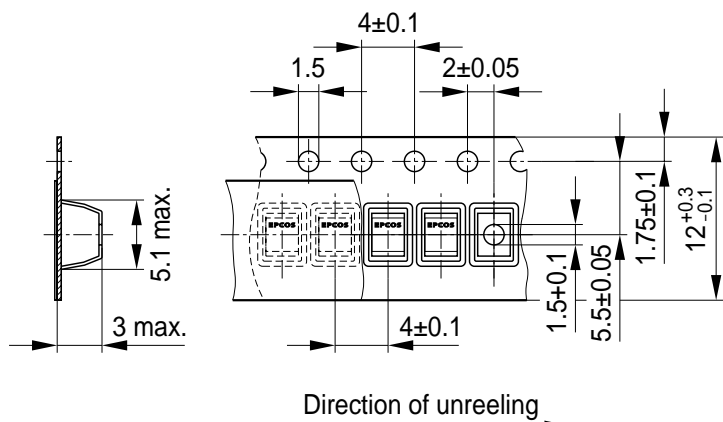

IND0881-C-E

Reel

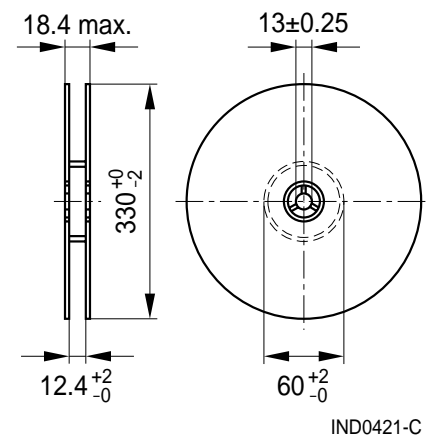

IND0421-C

Dimensions in mm

SIMDAD 1210, common-mode chokes

Preliminary data

SMD
Technical data and measuring conditions

Rated voltage V_R	42 V AC (50/60 Hz) / 80 V DC
Test voltage V_{test}	250 V DC, 2 s (line/line)
Rated temperature T_R	110 °C
Rated current I_R	Referred to 50 Hz and rated temperature
Rated inductance L_R	Measured with Agilent 4284A at 100 kHz, 0.1 mA, 20 °C Inductance is specified per winding.
Inductance tolerance	-30/+50% at 20 °C
Inductance decrease $\Delta L/L_0$	Common mode < 10% at DC magnetic bias with I_R , 20 °C
Stray inductance $L_{stray,typ}$	Measured with Agilent 4284A at 100 kHz, 5 mA, 20 °C, typical values
DC resistance R_{max}	Measured at 20 °C, specified per winding
Solderability (lead-free)	Dip and look method Sn95.5Ag3.8Cu0.7: (245 ±5) °C, (3 ±0.3) s Wetting of soldering area ≥ 90% (based on IEC 60068-2-58)
Resistance to soldering heat	260 °C, 40 s as referenced in JEDEC J-STD 020C
Climatic category	-55/+150/56 (to IEC 60068-1)
Storage conditions	Mounted: -55 °C ... +150 °C, Packaged: -25 °C ... +40 °C, ≤ 75% RH
Weight	Approx. 0.06 g

Characteristics and ordering codes

L_R μH	L_{stray} μH	I_R mA	R_{max} mΩ	Ordering code Tinned terminals
11	0.10	300	250	B82788C0113H052
22	0.10	250	450	B82788C0223H052
22	2.50	250	450	B82788S0223H052
51	0.15	150	1400	B82788C0513H052
100	0.20	150	1500	B82788C0104H052

SIMDAD 1210, common-mode chokes

Preliminary data

SMD

Insertion loss α (typical values at $|Z| = 50 \Omega$, 20°C)

———— asymmetrical, both lines in parallel (common mode)

- - - - - symmetrical, both lines in series (differential mode)

$L_R = 11 \mu\text{H}$

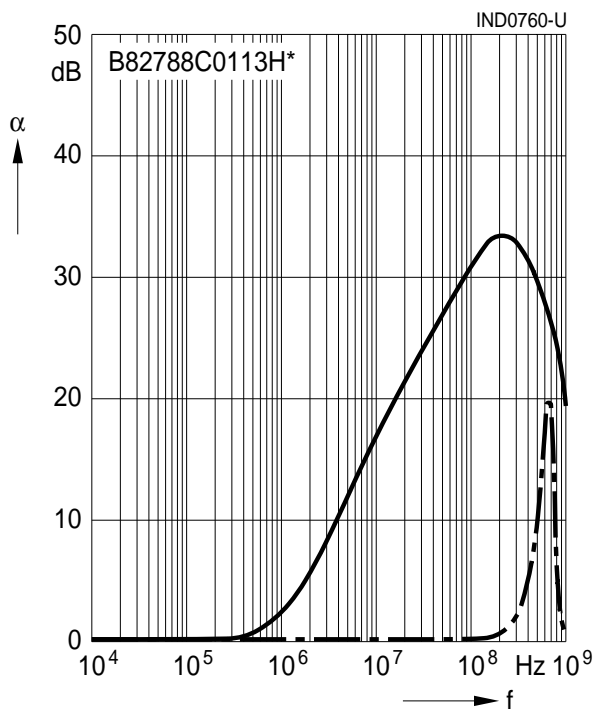

$L_R = 22 \mu\text{H}$ (low L_{stray})

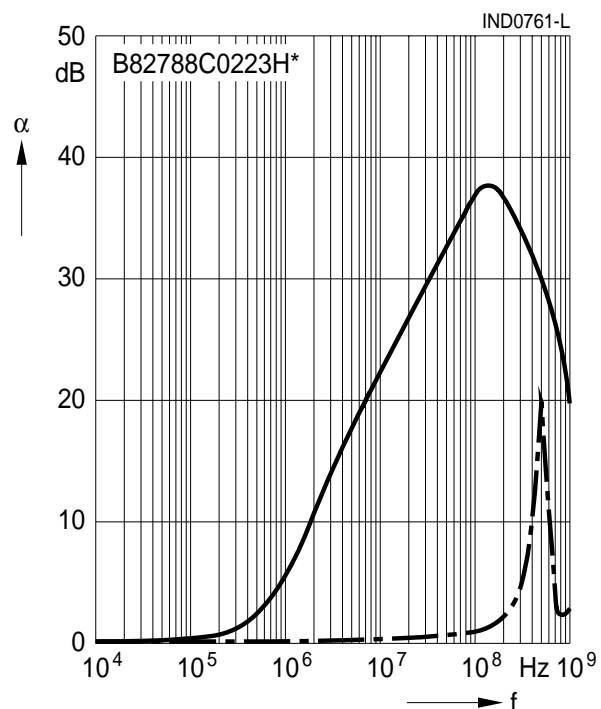

$L_R = 22 \mu\text{H}$ (high L_{stray})

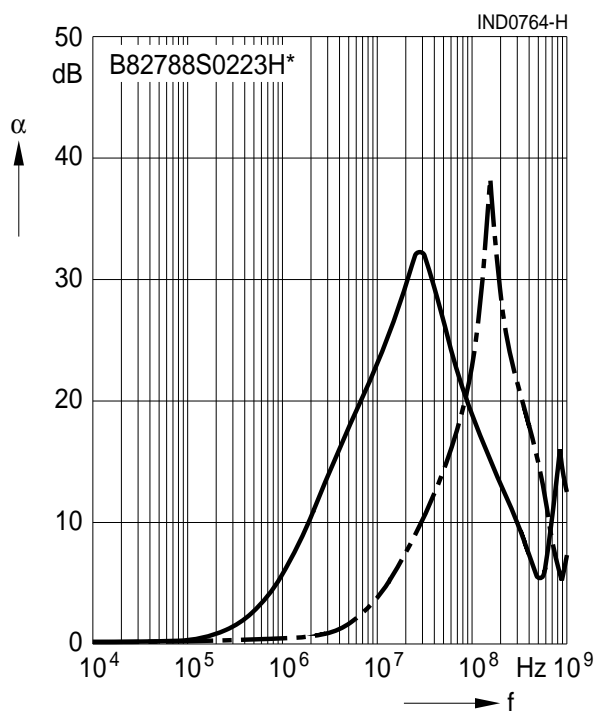

$L_R = 51 \mu\text{H}$

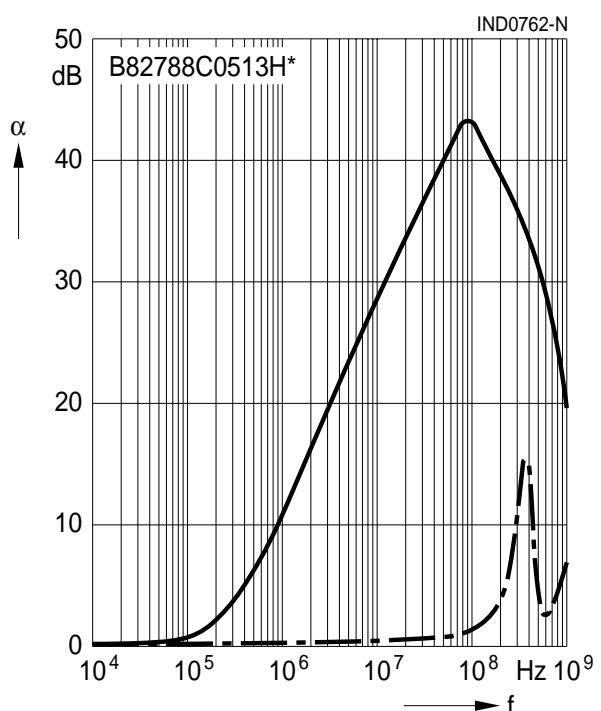

SIMDAD 1210, common-mode chokes

Preliminary data

SMD

Insertion loss α (typical values at $|Z| = 50 \Omega$, 20 °C)

———— asymmetrical, both lines in parallel (common mode)

- - - - - symmetrical, both lines in series (differential mode)

$L_R = 100 \mu\text{H}$

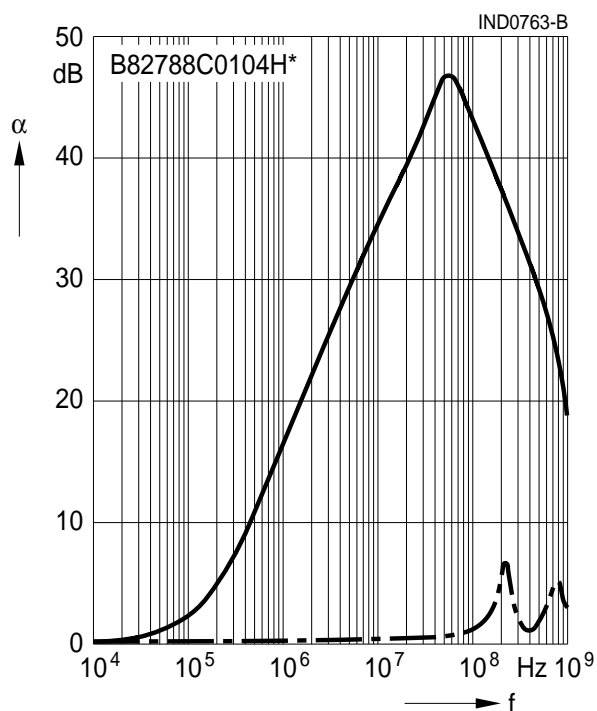

Current derating I_{op}/I_R versus ambient temperature (rated temperature $T_R = 110 \text{ °C}$)

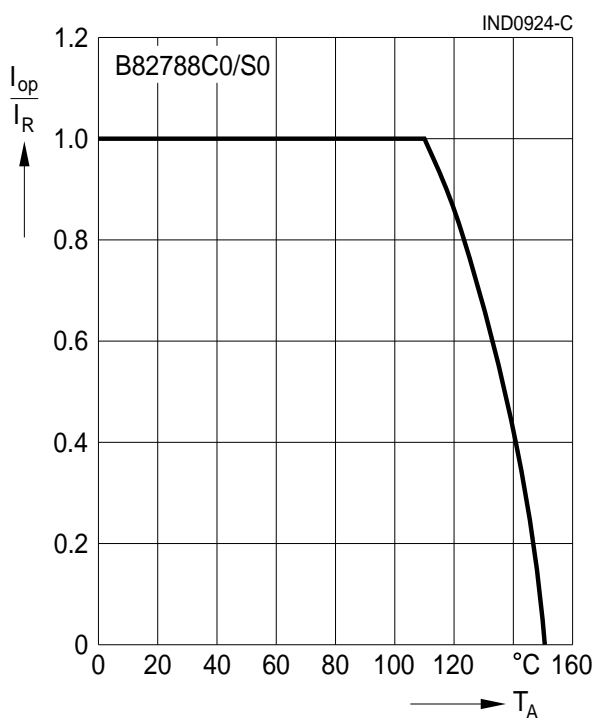

Cautions and warnings

- Please note the recommendations in our Inductors data book (latest edition) and in the data sheets.
 - Particular attention should be paid to the derating curves given there.
 - The soldering conditions should also be observed. Temperatures quoted in relation to wave soldering refer to the pin, not the housing.
- If the components are to be washed varnished it is necessary to check whether the washing varnish agent that is used has a negative effect on the wire insulation, any plastics that are used, or on glued joints. In particular, it is possible for washing varnish agent residues to have a negative effect in the long-term on wire insulation.
- The following points must be observed if the components are potted in customer applications:
 - Many potting materials shrink as they harden. They therefore exert a pressure on the plastic housing or core. This pressure can have a deleterious effect on electrical properties, and in extreme cases can damage the core or plastic housing mechanically.
 - It is necessary to check whether the potting material used attacks or destroys the wire insulation, plastics or glue.
 - The effect of the potting material can change the high-frequency behaviour of the components.
- Ferrites are sensitive to direct impact. This can cause the core material to flake, or lead to breakage of the core.
- Even for customer-specific products, conclusive validation of the component in the circuit can only be carried out by the customer.

Important notes

The following applies to all products named in this publication:

1. Some parts of this publication contain **statements about the suitability of our products for certain areas of application**. These statements are based on our knowledge of typical requirements that are often placed on our products in the areas of application concerned. We nevertheless expressly point out **that such statements cannot be regarded as binding statements about the suitability of our products for a particular customer application**.

As a rule, EPCOS is either unfamiliar with individual customer applications or less familiar with them than the customers themselves. For these reasons, it is always ultimately incumbent on the customer to check and decide whether an EPCOS product with the properties described in the product specification is suitable for use in a particular customer application.

2. We also point out that **in individual cases, a malfunction of electronic components or failure before the end of their usual service life cannot be completely ruled out in the current state of the art, even if they are operated as specified**. In customer applications requiring a very high level of operational safety and especially in customer applications in which the malfunction or failure of an electronic component could endanger human life or health (e.g. in accident prevention or life-saving systems), it must therefore be ensured by means of suitable design of the customer application or other action taken by the customer (e.g. installation of protective circuitry or redundancy) that no injury or damage is sustained by third parties in the event of malfunction or failure of an electronic component.
3. **The warnings, cautions and product-specific notes must be observed.**
4. In order to satisfy certain technical requirements, **some of the products described in this publication may contain substances subject to restrictions in certain jurisdictions (e.g. because they are classed as hazardous)**. Useful information on this will be found in our Material Data Sheets on the Internet (www.epcos.com/material). Should you have any more detailed questions, please contact our sales offices.
5. We constantly strive to improve our products. Consequently, **the products described in this publication may change from time to time**. The same is true of the corresponding product specifications. Please check therefore to what extent product descriptions and specifications contained in this publication are still applicable before or when you place an order.

We also **reserve the right to discontinue production and delivery of products**. Consequently, we cannot guarantee that all products named in this publication will always be available.

The aforementioned does not apply in the case of individual agreements deviating from the foregoing for customer-specific products.

6. Unless otherwise agreed in individual contracts, **all orders are subject to the current version of the “General Terms of Delivery for Products and Services in the Electrical Industry” published by the German Electrical and Electronics Industry Association (ZVEI)**.
7. The trade names EPCOS, BAOKE, Alu-X, CeraDiode, CSMP, CSSP, CTVS, DSSP, MiniBlue, MKK, MLSC, MotorCap, PCC, PhaseCap, PhaseCube, PhaseMod, SIFERRIT, SIFI, SIKOREL, SilverCap, SIMDAD, SIMID, SineFormer, SIOV, SIP5D, SIP5K, ThermoFuse, WindCap are **trademarks registered or pending** in Europe and in other countries. Further information will be found on the Internet at www.epcos.com/trademarks.