



## **SMT inductors**

SIMID series, SIMID 1210-01

**Series/Type:** B82412A

**Date:** March 2008

**SIMID 1210-01**

**SMD**

**Size 1210 (EIA) or 3225 (IEC)**  
**Rated inductance 0.010  $\mu$ H to 10  $\mu$ H**  
**Rated current 90 mA to 700 mA**

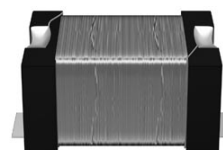

**Construction**

- Ceramic or ferrite core
- Single-layer winding fixed by glue
- Ultrasonic-welded winding

**Features**

- Low height
- High Q factor
- High resonance frequency
- Suitable for lead-free reflow soldering as referenced in JEDEC J-STD 020C
- RoHS-compatible

**Applications**

- Filtering of supply voltages, coupling, decoupling
- Antenna systems
- Infotainment
- Telecommunications
- Industrial electronics

**Terminals**

- Base material CuSn6
- Layer composition Cu, Ag (lead-free)
- Electro-plated

**Marking**

- No marking on component
- Minimum data on reel:  
Manufacturer, ordering code, L value,  
quantity, date of packing

**Delivery mode and packing units**

- 8-mm blister tape, wound on 180-mm or 330-mm  $\varnothing$  reel
- Packing units:  
180-mm reel: 2500 pcs./reel  
330-mm reel: 10000 pcs./reel

**SMD**

**Dimensional drawing and layout recommendation**

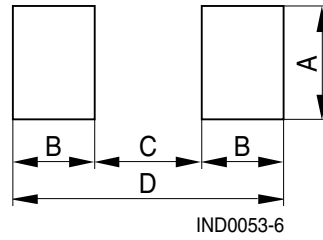
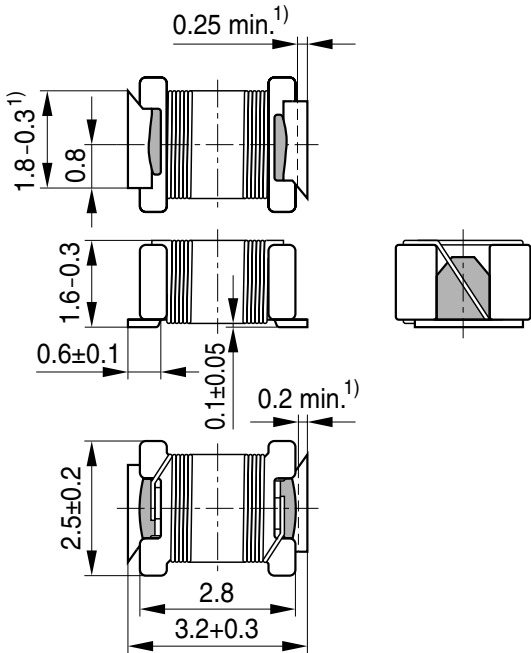

IND0053-6

A	B	C	D
2.7	1.15	2.1	4.4

1) Soldering area

IND0052-V-E

Dimensions in mm

**Taping and packing**

Blister tape

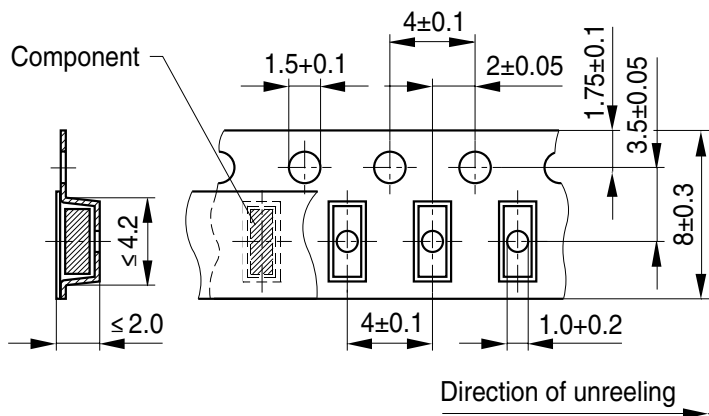

IND0570-T-E

Reel

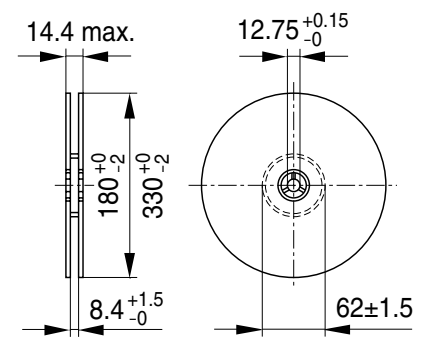

IND0592-V

Dimensions in mm

**SMD**
**Technical data and measuring conditions**

Rated inductance $L_R$	Measured with impedance analyzer Agilent 4294A at frequency $f_L$ , 0.1 V, 20 °C
Q factor $Q_{\min}$	Measured with impedance analyzer Agilent 4294A at frequency $f_Q$ , 20 °C
Rated temperature $T_R$	85 °C
Rated current $I_R$	Maximum permissible DC with inductance decrease $\Delta L/L_0 \leq 10\%$ and temperature increase of $\leq 20$ K at rated temperature
Self-resonance frequency $f_{\text{res,min}}$	Measured with network analyzer Agilent 8753D, 20 °C
DC resistance $R_{\max}$	Measured at 20 °C
Solderability (lead-free)	Sn95.5Ag3.8Cu0.7: (245 ±5) °C, (5 ±0.3) s Wetting of soldering area $\geq 95\%$ (based on IEC 60068-2-58)
Resistance to soldering heat	260 °C, 40 s (as referenced in JEDEC J-STD 020C)
Climatic category	55/125/56 (to IEC 60068-1)
Storage conditions	Mounted: -55 °C ... +125 °C Packaged: -25 °C ... +40 °C, $\leq 75\%$ RH
Weight	Approx. 40 mg

**Characteristics and ordering codes**

$L_R$ $\mu\text{H}$	Tolerance	$f_L$ MHz	$Q_{\min}$	$f_Q$ MHz	$I_R$ mA	$R_{\max}$ $\Omega$	$f_{\text{res,min}}$ MHz	Ordering code <sup>1)</sup> ( $\varnothing$ 180-mm reel)
Core material: ceramic								
0.010	$\pm 20\% \triangle M$	10	25	100	700	0.10	4000	B82412A3100M000
0.012		10	25	100	700	0.10	3500	B82412A3120M000
0.015		10	25	100	640	0.12	3000	B82412A3150M000
0.018		10	30	100	640	0.12	2700	B82412A3180M000
0.022	$\pm 5\% \triangle J$ $\pm 10\% \triangle K$	10	30	100	600	0.12	2400	B82412A3220+000
0.027		10	20	50	600	0.15	2200	B82412A3270+000
0.033		10	25	50	540	0.17	2000	B82412A3330+000
0.039		10	25	50	500	0.18	1700	B82412A3390+000
0.047		10	25	50	470	0.22	1600	B82412A3470+000
0.056		10	30	50	460	0.23	1400	B82412A3560+000
0.068		10	30	50	440	0.25	1350	B82412A3680+000
0.082		10	30	50	430	0.27	1100	B82412A3820+000
0.10		10	30	50	400	0.30	1000	B82412A3101+000
0.12		1	25	30	380	0.35	900	B82412A3121+000
0.15		1	25	30	370	0.36	820	B82412A3151+000
0.18		1	25	30	340	0.42	700	B82412A3181+000
0.22		1	25	30	320	0.48	630	B82412A3221+000
0.27		1	30	30	300	0.55	570	B82412A3271+000
0.33		1	30	30	280	0.65	550	B82412A3331+000
0.39		1	30	30	260	0.75	500	B82412A3391+000
0.47		1	30	30	225	1.00	450	B82412A3471+000
0.56		1	30	30	200	1.20	430	B82412A3561+000
0.68		1	30	30	180	1.40	400	B82412A3681+000
0.82	1	30	30	150	2.00	380	B82412A3821+000	

Closer tolerances and special versions on request.

1) Replace the + by the code letter for the required inductance tolerance.  
For reel size  $\varnothing$  330 mm the last digit has to be an »8«. Example: B82412A3100M008

**Characteristics and ordering codes**

$L_R$ $\mu\text{H}$	Tolerance	$f_L$ MHz	$Q_{\min}$	$f_Q$ MHz	$I_R$ mA	$R_{\max}$ $\Omega$	$f_{\text{res,min}}$ MHz	Ordering code <sup>1)</sup> ( $\varnothing$ 180-mm reel)
Core material: ferrite								
1.0	$\pm 5\% \triangle J$	1	30	7.96	330	0.45	300	B82412A1102+000
1.2	$\pm 10\% \triangle K$	1	30	7.96	310	0.50	260	B82412A1122+000
1.5		1	30	7.96	300	0.55	240	B82412A1152+000
1.8		1	30	7.96	290	0.60	220	B82412A1182+000
2.2		1	30	7.96	270	0.65	200	B82412A1222+000
2.7		1	30	7.96	220	1.05	180	B82412A1272+000
3.3		1	30	7.96	200	1.10	160	B82412A1332+000
3.9		1	30	7.96	190	1.35	150	B82412A1392+000
4.7		1	35	7.96	160	1.80	140	B82412A1472+000
5.6		1	35	7.96	140	2.70	125	B82412A1562+000
6.8		1	35	7.96	120	3.50	115	B82412A1682+000
8.2		1	35	7.96	110	3.80	100	B82412A1822+000
10		1	35	7.96	90	5.50	95	B82412A1103+000

Closer tolerances and special versions on request.

1) Replace the + by the code letter for the required inductance tolerance.  
For reel size  $\varnothing$  330 mm the last digit has to be an »8«. Example: B82412A1102M008

**SMD**

**Impedance  $|Z|$  versus frequency  $f$**   
measured with impedance analyzer  
Agilent 4291A, typical values at 20 °C

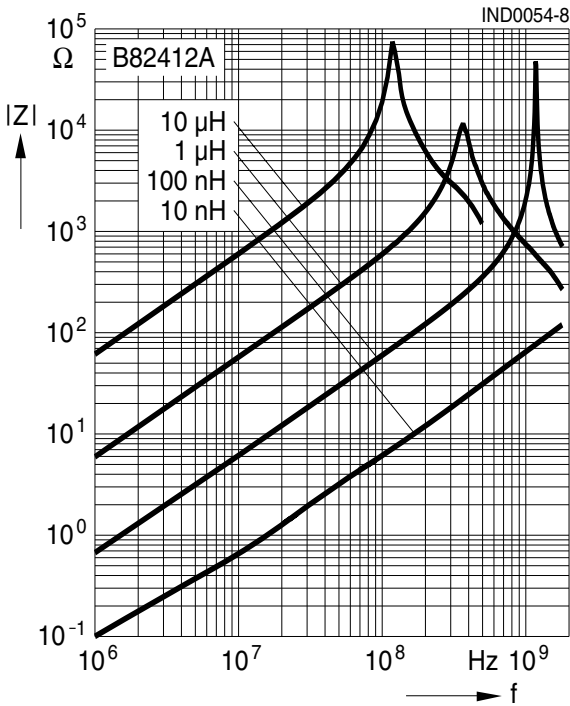

**Inductance  $L$  versus DC load current  $I_{DC}$**   
measured with LCR meter Agilent 4275A,  
typical values at 20 °C

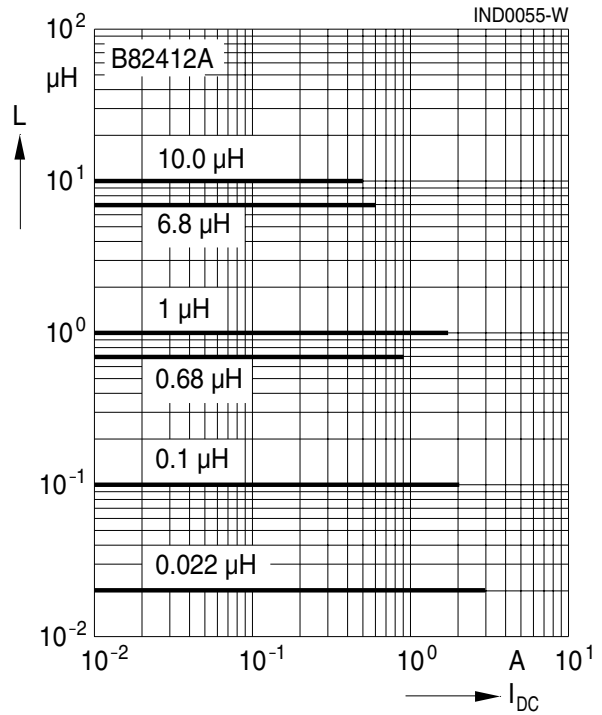

**Q factor versus frequency  $f$**   
measured with impedance analyzer Agilent  
4194A/4291A, typical values at 20 °C

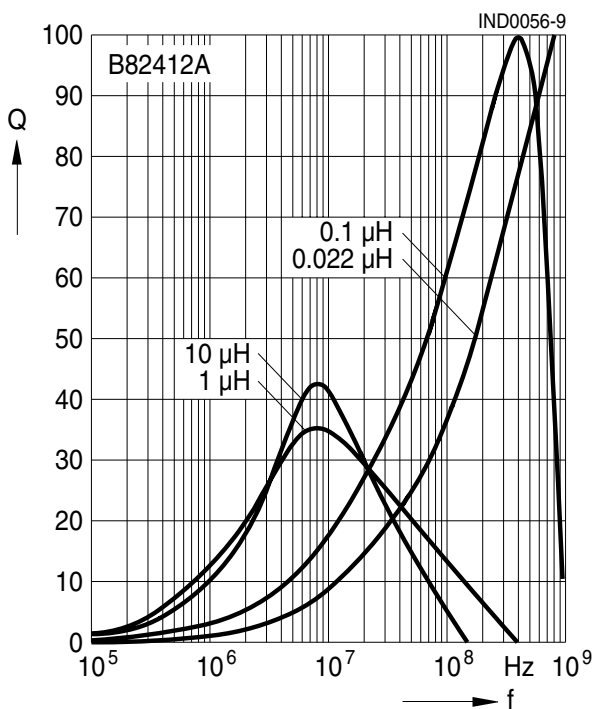

**Current derating  $I_{op}/I_R$**   
**versus ambient temperature  $T_A$**   
(rated temperature  $T_R = 85 °C$ )

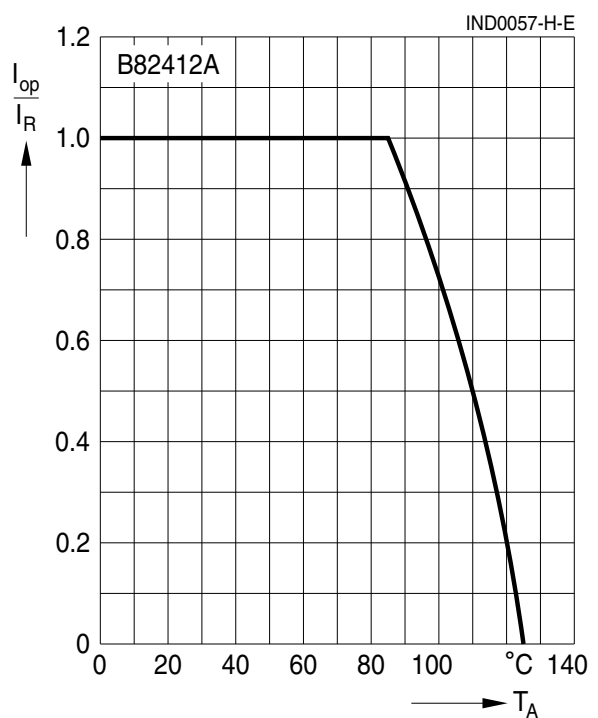

## Cautions and warnings

- Please note the recommendations in our Inductors data book (latest edition) and in the data sheets.
  - Particular attention should be paid to the derating curves given there.
  - The soldering conditions should also be observed. Temperatures quoted in relation to wave soldering refer to the pin, not the housing.
- If the components are to be washed varnished it is necessary to check whether the washing varnish agent that is used has a negative effect on the wire insulation, any plastics that are used, or on glued joints. In particular, it is possible for washing varnish agent residues to have a negative effect in the long-term on wire insulation.
- The following points must be observed if the components are potted in customer applications:
  - Many potting materials shrink as they harden. They therefore exert a pressure on the plastic housing or core. This pressure can have a deleterious effect on electrical properties, and in extreme cases can damage the core or plastic housing mechanically.
  - It is necessary to check whether the potting material used attacks or destroys the wire insulation, plastics or glue.
  - The effect of the potting material can change the high-frequency behaviour of the components.
- Ferrites are sensitive to direct impact. This can cause the core material to flake, or lead to breakage of the core.
- Even for customer-specific products, conclusive validation of the component in the circuit can only be carried out by the customer.

## Important notes

The following applies to all products named in this publication:

1. Some parts of this publication contain **statements about the suitability of our products for certain areas of application**. These statements are based on our knowledge of typical requirements that are often placed on our products in the areas of application concerned. We nevertheless expressly point out **that such statements cannot be regarded as binding statements about the suitability of our products for a particular customer application**.

As a rule, EPCOS is either unfamiliar with individual customer applications or less familiar with them than the customers themselves. For these reasons, it is always ultimately incumbent on the customer to check and decide whether an EPCOS product with the properties described in the product specification is suitable for use in a particular customer application.

2. We also point out that **in individual cases, a malfunction of electronic components or failure before the end of their usual service life cannot be completely ruled out in the current state of the art, even if they are operated as specified**. In customer applications requiring a very high level of operational safety and especially in customer applications in which the malfunction or failure of an electronic component could endanger human life or health (e.g. in accident prevention or life-saving systems), it must therefore be ensured by means of suitable design of the customer application or other action taken by the customer (e.g. installation of protective circuitry or redundancy) that no injury or damage is sustained by third parties in the event of malfunction or failure of an electronic component.
3. **The warnings, cautions and product-specific notes must be observed.**
4. In order to satisfy certain technical requirements, **some of the products described in this publication may contain substances subject to restrictions in certain jurisdictions (e.g. because they are classed as hazardous)**. Useful information on this will be found in our Material Data Sheets on the Internet ([www.epcos.com/material](http://www.epcos.com/material)). Should you have any more detailed questions, please contact our sales offices.
5. We constantly strive to improve our products. Consequently, **the products described in this publication may change from time to time**. The same is true of the corresponding product specifications. Please check therefore to what extent product descriptions and specifications contained in this publication are still applicable before or when you place an order.

We also **reserve the right to discontinue production and delivery of products**. Consequently, we cannot guarantee that all products named in this publication will always be available.

The aforementioned does not apply in the case of individual agreements deviating from the foregoing for customer-specific products.

6. Unless otherwise agreed in individual contracts, **all orders are subject to the current version of the “General Terms of Delivery for Products and Services in the Electrical Industry” published by the German Electrical and Electronics Industry Association (ZVEI)**.
7. The trade names EPCOS, BAOKE, Alu-X, CeraDiode, CSMP, CSSP, CTVS, DSSP, MiniBlue, MKK, MLSC, MotorCap, PCC, PhaseCap, PhaseCube, PhaseMod, SIFERRIT, SIFI, SIKOREL, SilverCap, SIMDAD, SIMID, SineFormer, SIOV, SIP5D, SIP5K, ThermoFuse, WindCap are **trademarks registered or pending** in Europe and in other countries. Further information will be found on the Internet at [www.epcos.com/trademarks](http://www.epcos.com/trademarks).