

## Mounting Instructions

EMC cannot be assured by the use of EMC filters alone. Every system should be considered as an integrated whole and careful planning and preparation are required to ensure success. Measures such as shielded motor leads, grounding and spatial separation are mandatory parts of an integrated concept.

### Plan your EMC!

- Identify interference sources (with interference emissions) and disturbed equipment (electrical equipment or components with limited interference immunity).
- Assign interference sources and disturbed equipment to specific mounting locations and separate them spatially from each other.
- Plan the cabling in wiring categories in accordance with interference emissions and interference immunity.

**EMC is an indispensable quality feature!** The legally stipulated protection objectives and technical risks must be taken into consideration as early as the development stage.

In order to achieve electromagnetic compatibility of the overall system the following points must be observed:

1. The **filter case should be connected across a large area to ground and to the other equipment.**

For example, a blank metal mounting plate should be provided jointly for filters and converters. It should be well grounded and connected to the switch cabinet via a large-area low-inductance connection. If necessary, use short copper tapes and EMC seals (e.g. connection to switch cabinet doors).

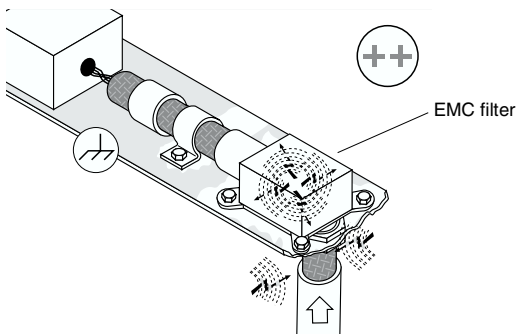

2. A distinction should be made between

- the protective earth connection of the EMC filter (see also requirements on the PE connection in the chapter “General”, [Section 8.4, page 60](#)), which is used to secure protection against hazardous body currents, and
- the large-area grounding of the filter, which is required for its interference suppression function.

The figures in the chapter “Mounting instructions” were made available by Rittal-Werk, Herborn and Euratherm Regler GmbH, Limburg/Lahn.

## Mounting Instructions

3. In your system, set up **connections at the same reference potential** in order to reduce galvanically coupled interference. All metallic reference potentials of housings, machines and installations should be linked via a low-impedance connection with RF capability and intermeshed as far as possible.

Set up large-area metallic connections, use equipotential busbars and set up short connections via ribbon-type grounding cables.

The following conditions apply:

- large-area ground connection,
- low-inductance connection  
(give preference to a rectangular copper ribbon over circular conductors),
- short connections (rule of thumb: length divided by width < 3).

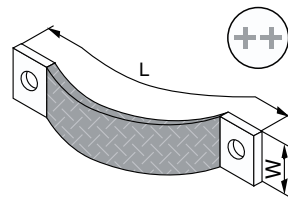
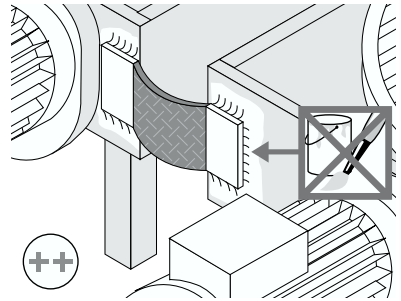
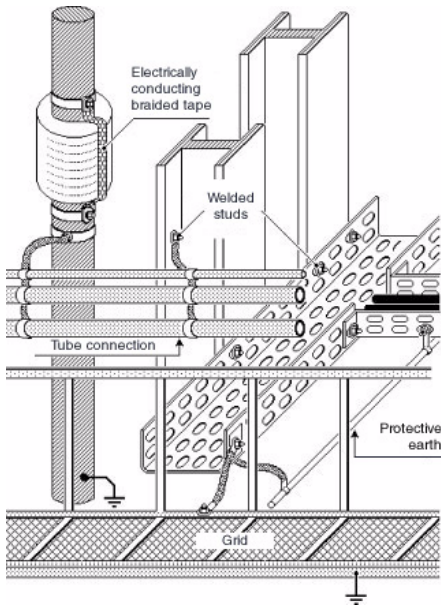

$$\frac{L}{W} < 3$$

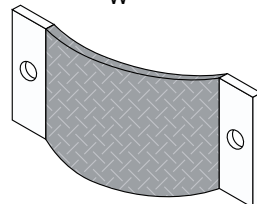

## Mounting Instructions

### 4. Keep cables from the interference source as short as possible!

Examples:

- short connection from the converter to the EMC filter; ideally a flanged-on filter to avoid emissions.
- connection cables of minimum length between converter output and motor (also to reduce asymmetrical currents caused by the parasitic capacitances of the cable shield).

### 5. Interference-carrying cables must be shielded!

Examples:

- connection cables between frequency converter and motor, if no corresponding output filter is used.
- connection cables filter and converter on the line side, where not directly flanged on
- it should be noted that the shielding effect of different cables can differ widely (foil shield, shielded braiding with various coverings, combinations).

### 6. Connect shielded cables on both sides and across a large-area with reference potential, as far as possible directly or close to the input or output sides of the housing.

Use

- EMC-compliant cable fittings (all-round contact)
- an EMC baseplate
- EMC shielded busbars with large-area contacting of the cable shield by suitable metal clips.

### Avoid shielded terminals connected via stub cables!

(Twisted shield braiding; soldered cable lugs etc.)

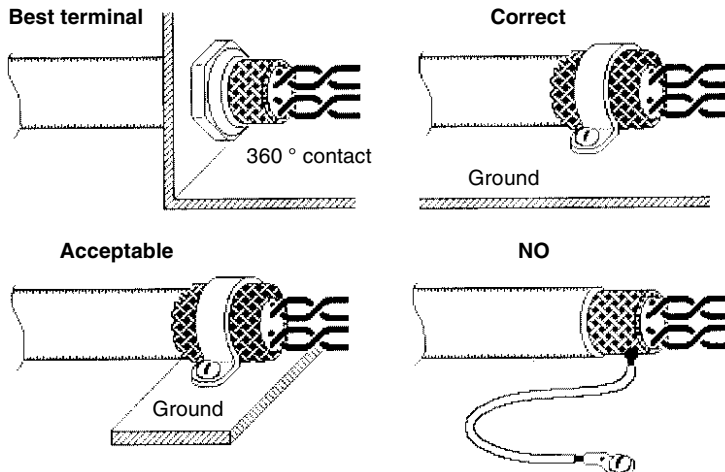

## Mounting Instructions

Ensure that an EMC-compliant cable screw terminal is provided at the motor terminal box. It must correspond to the protection mode for its respective location of use. The motor terminal box must not be made of plastic, the connection between cable screw terminal and terminal box must be of large-area design. If the lacquer has been removed, it may be necessary to restore the corrosion-protection layer.

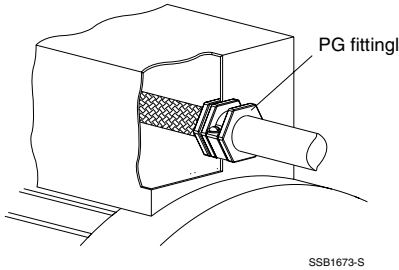

### 7. Configure EMC filters as far as possible directly at the entry or exit points of the housing

Examples:

- Line terminal side of the filter projects from the corresponding opening of the housing (ensure protection against body contact).
- Use of suitable EMC filters.
- Use of corresponding housing matching elements to ensure the required shielding attenuation (see Chapter “Application Notes, Example – marine applications”, [page 105](#)).

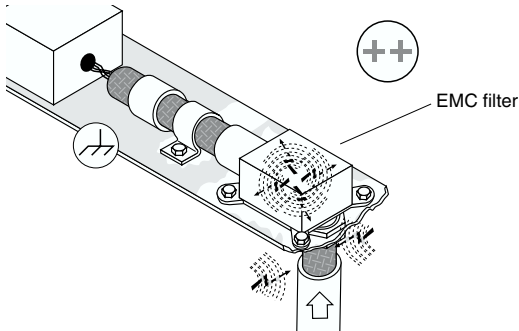

## Mounting Instructions

8. **Spatial separation** between interference-emitting and “clean” cables must be ensured (noisy cables include those between converter and filter, whereas “clean” cables include those between line terminal and filter).

Avoid running cables in parallel (to reduce coupled interference).

Note the spatially separated laying of signal and power cables in order to avoid coupling routes (minimum recommended spacing 20 cm). Use separating metal plates and ground them across a wide area if necessary.

As far as possible, run cable cross-overs at right angles and keep them well separated.

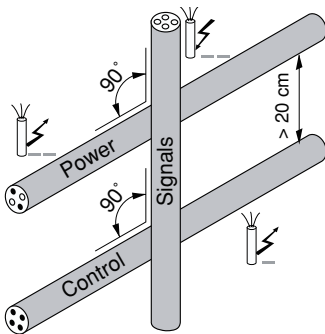
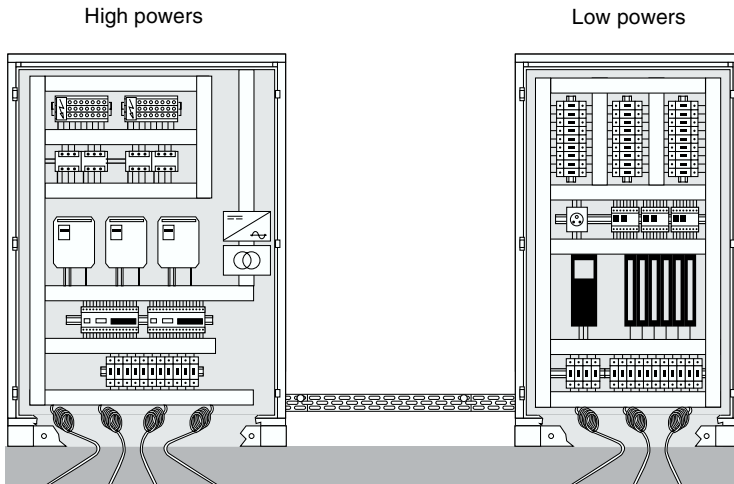

## Mounting Instructions

9. In order to reduce interference coupling, as far as possible run the cables close to **metal parts which are connected** to the reference potential (mounting plates, switch cabinet etc.)

Live cables should also be run as close as possible to the reference potential (to reduce inductively coupled interference).

In order to improve electromagnetic compatibility, preference should be given to cable ducts, cable troughs and installation tubes which are made of metal rather than plastic parts.

Open metallic cable duct

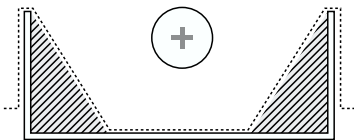

/// Regions with a good shielding effect against electromagnetic fields

10. In the case of unshielded signal cables (forward and return lines) use twisted-pair lines in order to minimize the area between the wires (to avoid magnetic coupling). The same applies to avoiding loops.
11. Connect suitable EMC components close to switched inductors (e.g. contactors, relays, magnetic valves etc.).
12. For control signals in the vicinity of high interference levels, use transmission techniques such as:
- Differential-mode transmission systems with twisted-pair lines in conjunction with data line chokes (see also our data book “Chokes and Inductors”).
  - Transmission of digital signals according to the RS-422 standard or in extreme cases crossing the interference region with fiber-optic cables.

**Herausgegeben von EPCOS AG**

**Marketing Kommunikation, Postfach 80 17 09, 81617 München, DEUTSCHLAND**

© EPCOS AG 2000. Alle Rechte vorbehalten. Vervielfältigung, Veröffentlichung, Verbreitung und Verwertung dieser Broschüre und ihres Inhalts ohne ausdrückliche Genehmigung der EPCOS AG nicht gestattet.

Mit den Angaben in dieser Broschüre werden die Bauelemente spezifiziert, keine Eigenschaften zugesichert. Bestellungen unterliegen den vom ZVEI empfohlenen Allgemeinen Lieferbedingungen für Erzeugnisse und Leistungen der Elektroindustrie, soweit nichts anderes vereinbart wird.

Diese Broschüre ersetzt die vorige Ausgabe.

Fragen über Technik, Preise und Liefermöglichkeiten richten Sie bitte an den Ihnen nächstgelegenen Vertrieb der EPCOS AG oder an unsere Vertriebsgesellschaften im Ausland.

Bauelemente können aufgrund technischer Erfordernisse Gefahrstoffe enthalten. Auskünfte darüber bitten wir unter Angabe des betreffenden Typs ebenfalls über die zuständige Vertriebsgesellschaft einzuholen.

**Published by EPCOS AG**

**Marketing Communications, P.O. Box 80 17 09, 81617 Munich, GERMANY**

© EPCOS AG 2000. All Rights Reserved. Reproduction, publication and dissemination of this brochure and the information contained therein without EPCOS' prior express consent is prohibited.

The information contained in this brochure describes the type of component and shall not be considered as guaranteed characteristics. Purchase orders are subject to the General Conditions for the Supply of Products and Services of the Electrical and Electronics Industry recommended by the ZVEI (German Electrical and Electronic Manufacturers' Association), unless otherwise agreed.

This brochure replaces the previous edition.

For questions on technology, prices and delivery please contact the Sales Offices of EPCOS AG or the international Representatives.

Due to technical requirements components may contain dangerous substances. For information on the type in question please also contact one of our Sales Offices.