



Film capacitors – Power Factor Correction

Key components – Capacitor contactors

Series/Type: B44066S
Ordering code: B44066S....J230/J110/N230
Date: May 2009
Version: 7

Series B44066S....J230/J110
for conventional PFC-systems without reactors

Characteristics

- Excellent damping of inrush current
- Improved power quality (e.g. avoidance of voltage sags)
- Longer useful life of main contacts of capacitor contactor
- Soft switching of capacitor and thus longer useful life
- Enhanced mean life expectancy
- Reduced ohmic losses
- Easy access for cable connection



B44066S....J230/J110

Features	
Resistors	Tamper-proof and protected
Leading contacts	With wiper function
Pre-contacts	Snap function
Aux-contacts	For all types
Usage	In applications with or without reactors



B44066S9910J230

Series B44066S....N230
for detuned PFC-systems with reactors

Characteristics

- Cost efficient
- Optimized for capacitor switching
- Long useful life of main contacts of capacitor contactor
- Easy access for cable connection

Features	
Aux-contacts	For all types
Usage	In applications with reactors only



B44066S....N230/N110

Technical Data

To IEC 947-4-1, IEC 947-5-1, EN 60947-4-1, EN 60947-5-1, VDE 0660

Type/ Main contacts		...1810...	...2410...	...3210...	...5010...	...6210...	...7410...	...9910...
Capacitor power at 50 °C								
■ 380 ... 400 V	kvar	0 ... 12.5	10 ... 20	10 ... 25	20 ... 33.3	20 ... 50	20 ... 75	33 ... 100
■ 415 ... 440 V		0 ... 13	10.5 ... 22	10.5 ... 27	23 ... 36	23 ... 53	23 ... 75	36 ... 103
■ 660 ... 690 V		0 ... 20	17 ... 33	17 ... 41	36 ... 55	36 ... 82	36 ... 120	57 ... 170
Capacitor power at 60 °C								
■ 380 - 400 V	kvar	0 ... 12.5	10 ... 20	10 ... 25	20 ... 33.3	20 ... 50	20 ... 60	33 ... 90
■ 415 - 440 V		0 ... 13	10.5 ... 22	10.5 ... 27	23 ... 36	23 ... 53	23 ... 64	36 ... 93
■ 660 - 690 V		0 ... 20	17 ... 33	17 ... 41	36 ... 55	36 ... 82	36 ... 100	57 ... 148
Coil voltage at 50 Hz:								
■ Type ...J230	V AC	230 ±10	230 ±10	230 ±10	230 ±10	230 ±10	230 ±10	230 ±10
■ Type ...J110		110 -10	110 -10	110 -10	not avail.	110 -10	110 -10	not avail.
■ Type ...N230		230 ±10	230 ±10	230 ±10	230 ±10	230 ±10	230 ±10	230 ±10
Coil voltage at 60 Hz:								
■ Type ...J230	V AC	252 ±12	252 ±12	252 ±12	252 ±12	252 ±12	252 ±12	230 ±10
■ Type ...J110		110 +12	110 +12	110 +12	not avail.	110 +12	110 +12	not avail.
■ Type ...N230		252 ±12	252 ±12	252 ±12	252 ±12	252 ±12	252 ±12	230 ±10
Max. current at 50/60 Hz								
■ 50 °C	A	18	28	36	48	72	108	144
■ 60 °C		18	28	36	48	72	87	130
Power loss contactor at max. rated capacitor current	W	4.1	5.7	7.5	12.6	21	38.7	36
Rated insulation voltage	V AC	690 ¹	690 ¹	690 ¹	690 ¹	690 ¹	690 ¹	1000 ¹
Max. frequency of operations:	1/h	120	120	120	120	120	80	80
Contact life:	Million operations	0.25	0.15	0.15	0.15	0.15	0.12	0.075
Cable cross section								
■ Solid or stranded	mm ²	1.5 ... 6	2.5 ... 25	2.5 ... 25	4 ... 50	4 ... 50	4 ... 50	0.5 ... 95 / 10 ... 120
■ Flexible		1.5 ... 4	2.5 ... 16	2.5 ... 16	10 ... 35	10 ... 35	10 ... 35	0.5 ... 70 / 10 ... 95
■ Flexible with cable end sleeve		1.5 ... 4	2.5 ... 16	2.5 ... 16	10 ... 35	10 ... 35	10 ... 35	0.5 ... 70 / 10 ... 95
Cables / clamp		2	1	1	1	1	1	2
2 cables per clamp for cable cross section:								
■ Solid or stranded	mm ² (max.)	6/6	10/10	10/10	16/16	16/16	16/16	95/120
■ Flexible		4/4	10/10	10/10	25/25	25/25	25/25	70/95

¹ Applies to networks with grounded star point, over voltage category I to IV, pollution severity 3 (industrial standard),
V_{imp} = 6 kV. Values for other conditions are available on request.

Type/ Auxiliary contacts		...1810...	...2410...	...3210...	...5010...	...6210...	...7410...	...9910...
Operating range of magnet coils in multiples of control voltage		0.85 ... 1.1	0.85 ... 1.1	0.85 ... 1.1	0.85 ... 1.1	0.85 ... 1.1	0.85 ... 1.1	0.85 ... 1.1
Weight:								
■ Type ...N...	kg	0.23	0.50	0.50	0.9	0.9	0.9	2.3
■ Type ...J...		0.34	0.64	0.64	1.1	1.1	1.1	2.4
Normal Open (NO)		1	1	1	1	1	1	1
Rated insulation voltage	V AC	690 ²	690 ²	690 ²	690 ²	690 ²	690 ²	690 ²
Rated operational current, utilization category AC15:								
■ 220 ... 240 V	A	12	3	3	3	3	3	3
■ 380 ... 440 V	A	4	2	2	2	2	2	2
Thermal rated current at ambient temperature:								
■ 40 °C	A	16	10	10	10	10	10	10
■ 60 °C	A	12	6	6	6	6	6	6
Short circuit protection: Max. fuse size, slow, gL (gG)	A	25	20	20	20	20	20	20

² Applies to networks with grounded star point, over voltage category I to IV, pollution severity 3 (industrial standard), $V_{imp} = 6$ kV. Values for other conditions are available on request.

Connection diagram for all types B44066S....J...

(with preload resistors). (B44066S1810J230 and B44066S1810J110 with wires on the bottom only, B44066S9910J230 with resistors inside housing).

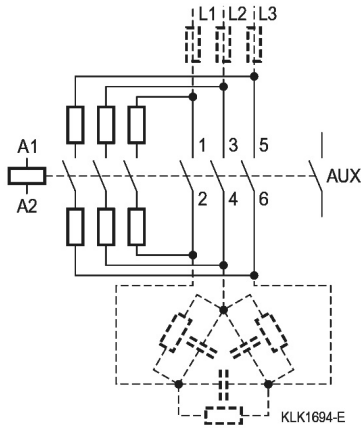

Connection diagram for all types B44066S...N...

(without preload resistors).

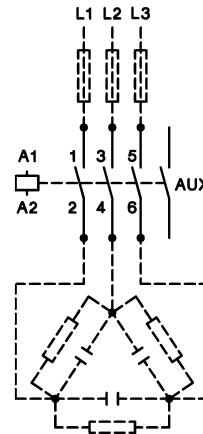

Dimensional drawings

B44066S1810J230, B44066S1810J110

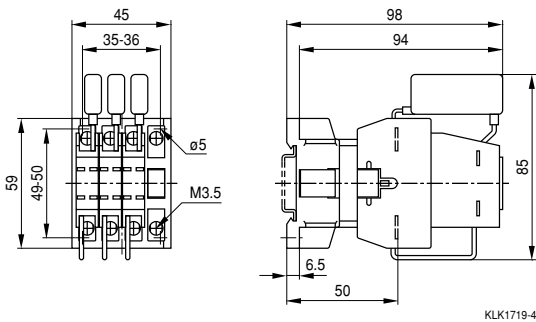

B44066S1810N230

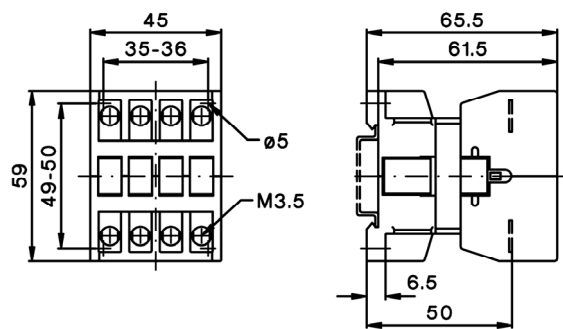

B44066S2410J230, B44066S3210J230

B44066S2410J110, B44066S3210J110

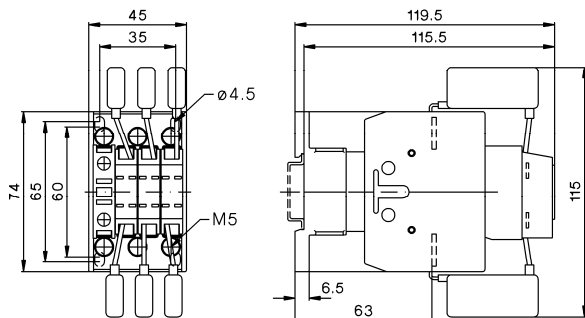

B44066S2410N230, B44066S3210N230

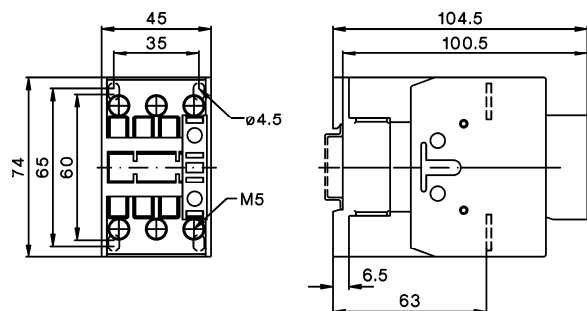

FK PC PM PFC

May 2009

B44066S5010J230,
B44066S6210J230, B44066S6210J110,
B44066S7410J230, B44066S7410J110

B44066S5010N230, B44066S6210N230
B44066S7410N230

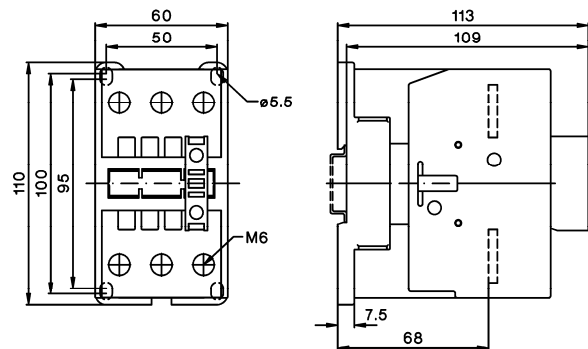
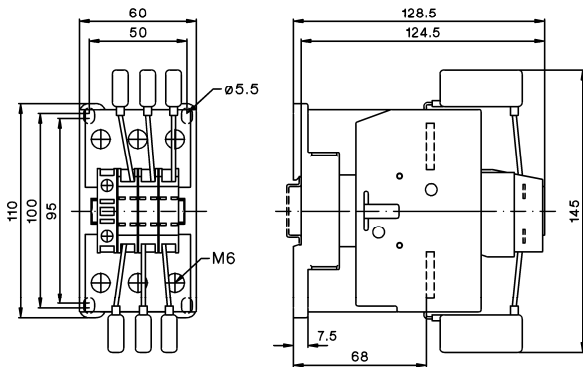

B44066S9910J230

B44066S9910N230

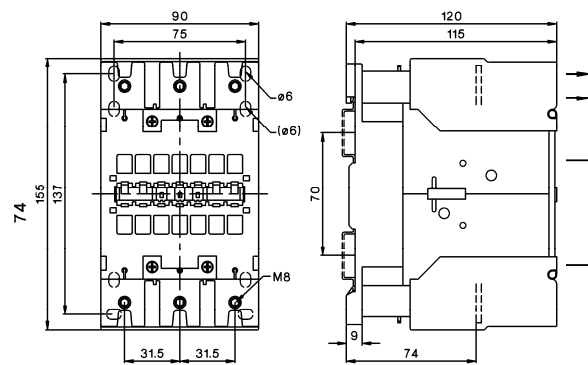
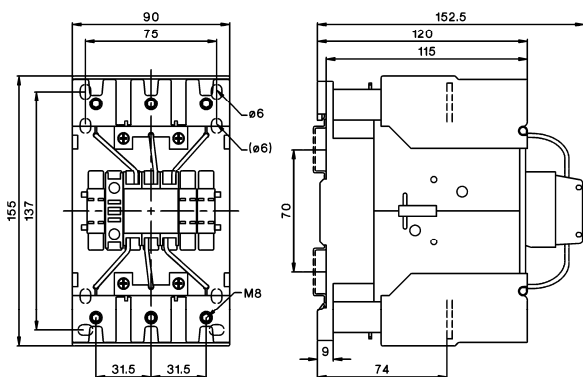

Cautions and warnings

In case auxiliary contacts are used for switching of discharge resistors (not in accordance with IEC 60831 standard), make sure that the current of the discharge resistors is not higher than the rated current of the auxiliary contacts.

Mounting instructions

In the area of capacitor switching contactors, difficultly inflammable and self-extinguishing materials may be used only, because abnormal temperatures within the area of the resistance spirals cannot be excluded.

Note

For detailed information about PFC capacitors and cautions, refer to the latest version of the EPCOS PFC Product Profile.

Important notes

The following applies to all products named in this publication:

1. Some parts of this publication contain **statements about the suitability of our products for certain areas of application**. These statements are based on our knowledge of typical requirements that are often placed on our products in the areas of application concerned. We nevertheless expressly point out **that such statements cannot be regarded as binding statements about the suitability of our products for a particular customer application**. As a rule, EPCOS is either unfamiliar with individual customer applications or less familiar with them than the customers themselves. For these reasons, it is always ultimately incumbent on the customer to check and decide whether an EPCOS product with the properties described in the product specification is suitable for use in a particular customer application.
2. We also point out that **in individual cases, a malfunction of electronic components or failure before the end of their usual service life cannot be completely ruled out in the current state of the art, even if they are operated as specified**. In customer applications requiring a very high level of operational safety and especially in customer applications in which the malfunction or failure of an electronic component could endanger human life or health (e.g. in accident prevention or life-saving systems), it must therefore be ensured by means of suitable design of the customer application or other action taken by the customer (e.g. installation of protective circuitry or redundancy) that no injury or damage is sustained by third parties in the event of malfunction or failure of an electronic component.
3. **The warnings, cautions and product-specific notes must be observed.**
4. In order to satisfy certain technical requirements, **some of the products described in this publication may contain substances subject to restrictions in certain jurisdictions (e.g. because they are classed as hazardous)**. Useful information on this will be found in our Material Data Sheets on the Internet (www.epcos.com/material). Should you have any more detailed questions, please contact our sales offices.
5. We constantly strive to improve our products. Consequently, **the products described in this publication may change from time to time**. The same is true of the corresponding product specifications. Please check therefore to what extent product descriptions and specifications contained in this publication are still applicable before or when you place an order. We also **reserve the right to discontinue production and delivery of products**. Consequently, we cannot guarantee that all products named in this publication will always be available. The aforementioned does not apply in the case of individual agreements deviating from the foregoing for customer-specific products.
6. Unless otherwise agreed in individual contracts, **all orders are subject to the current version of the "General Terms of Delivery for Products and Services in the Electrical Industry" published by the German Electrical and Electronics Industry Association (ZVEI)**.
7. The trade names EPCOS, BAOKE, Alu-X, CeraDiode, CSMP, CSSP, CTVS, DSSP, MiniBlue, MKK, MLSC, MotorCap, PCC, PhaseCap, PhaseCube, PhaseMod, SIFERRIT, SIFI, SIKOREL, SilverCap, SIMDAD, SIMID, SineFormer, SIOV, SIP5D, SIP5K, ThermoFuse, WindCap are **trademarks registered or pending** in Europe and in other countries. Further information will be found on the Internet at www.epcos.com/trademarks.